

Autorobot[®] Calipre

ELECTRONIC MEASURING

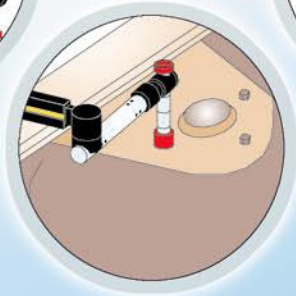
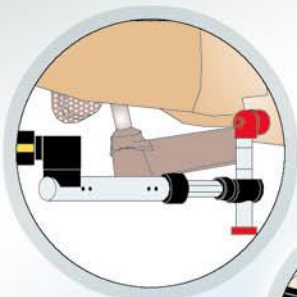
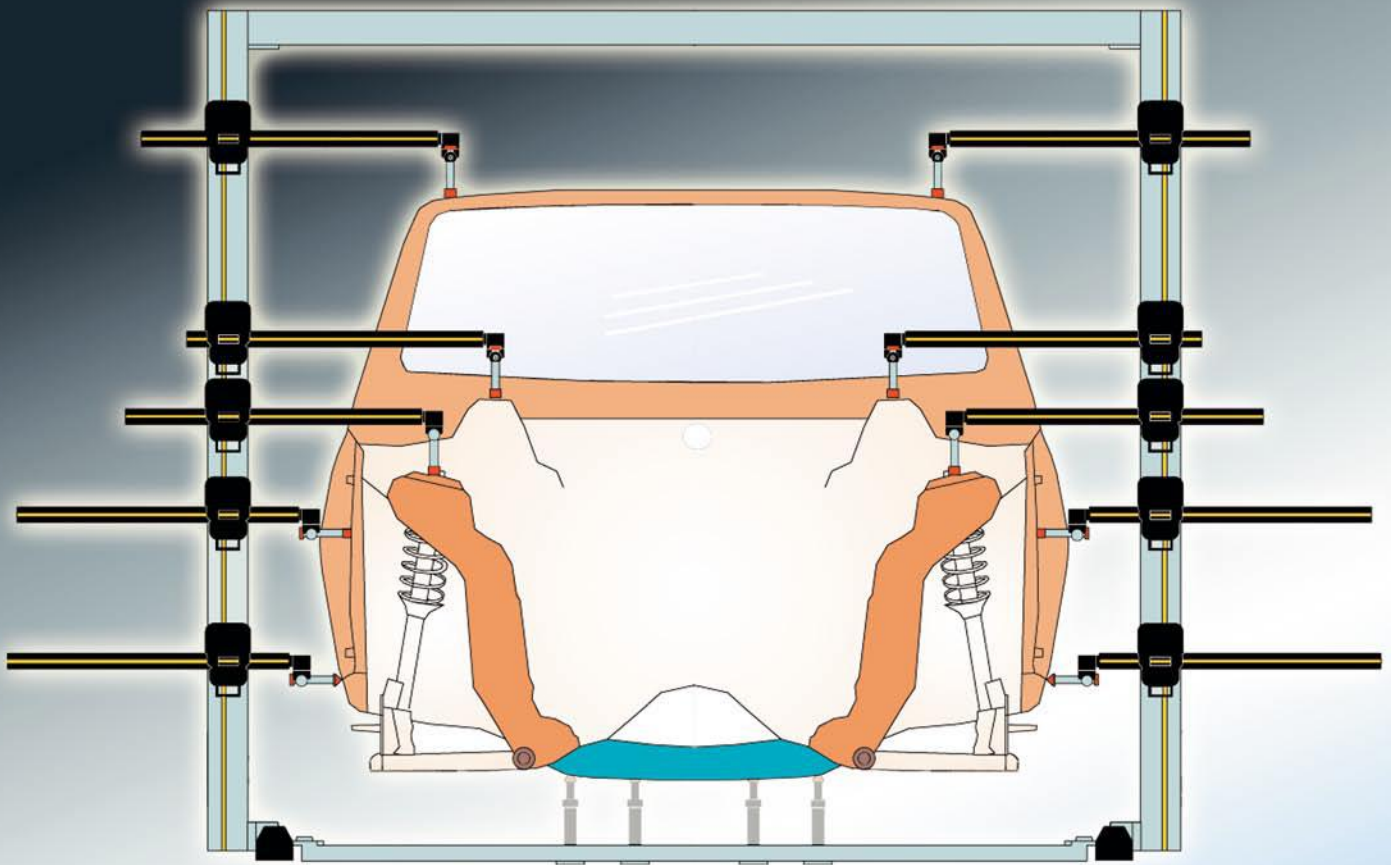

**Technology
from FINLAND**

Autorobot[®] Calipre

Calipre is Autorobot's advanced 3D electronic/mechanical measuring system. Its unique overhead arch moves over the entire vehicle, accurately measuring both chassis and body. Calipre's patented measuring heads streamline your shop's workflow, increasing production and ensuring accuracy.

Calipre's 3D measuring data is Autorobot's proprietary software; each vehicle's datasheet shows up to 60 measuring points per vehicle, plus mounting instructions. Our newest version includes photographs of late-model vehicles, detailing precise measuring points. Datasheet updates are available either on CD-ROM or online in Autorobot Extranet.

With Autorobot Calipre, measuring can be done either electronically or mechanically by hand (without computer). Vocational institutes, for example, find Autorobot Calipre perfect for teaching both measuring techniques with the same device. The system is easily moved between Autorobot benches and is workable in all circumstances. Calipre is unbeatable in speed and accuracy, for both the upper body and chassis measurements.

Autorobot Calipre 3D chassis and body measuring technique can be used also in other types of straightening systems by using an optional adapter kit.

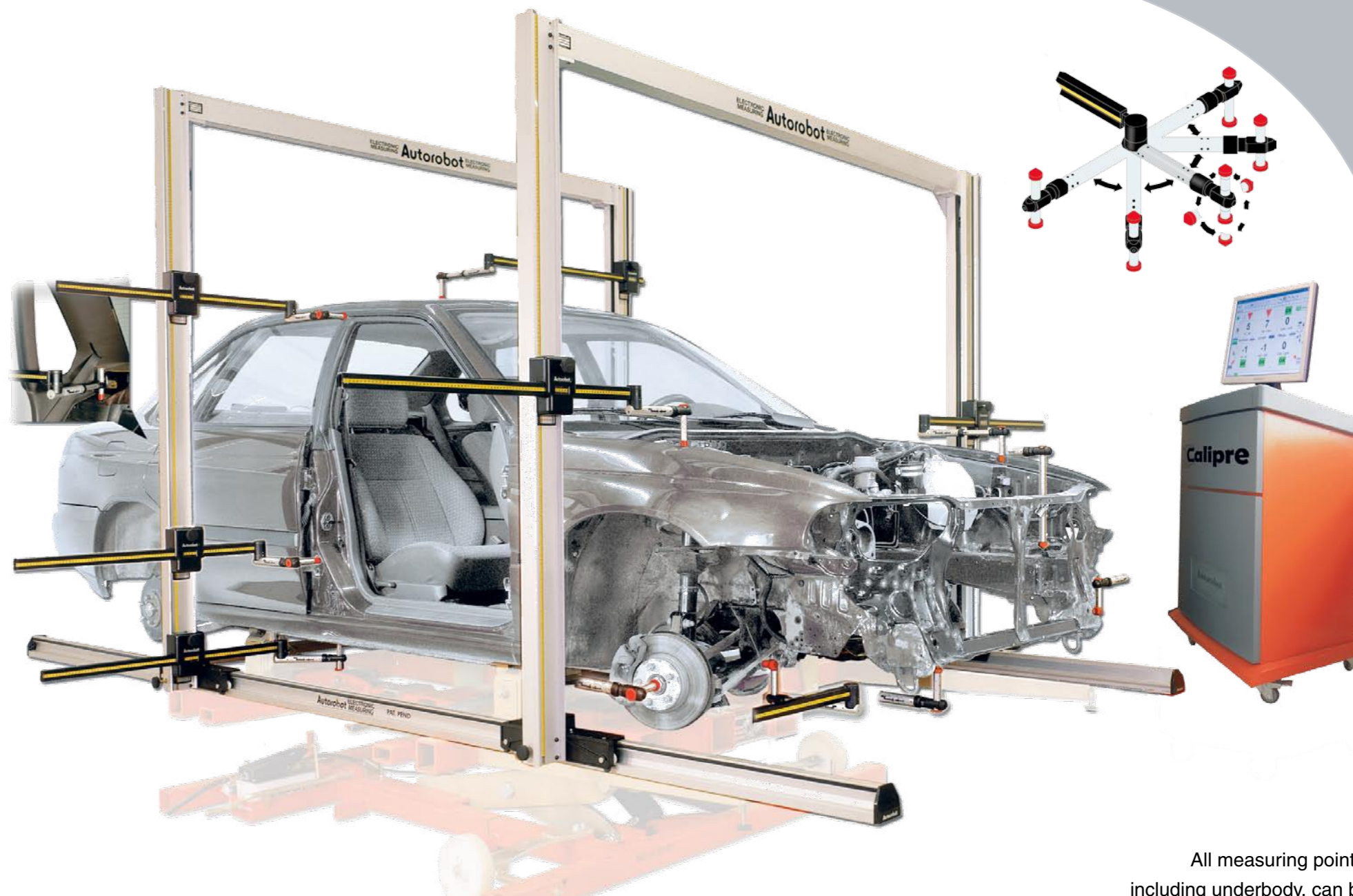

All measuring points, including underbody, can be reached comfortably from side of vehicle.

Patented



Cutting-edge repair with Autorobot B20, guided by Calipre. Bench lift and tower movements are controlled by hand-held wireless remote control. Measuring results are also transferred wirelessly to the computer.

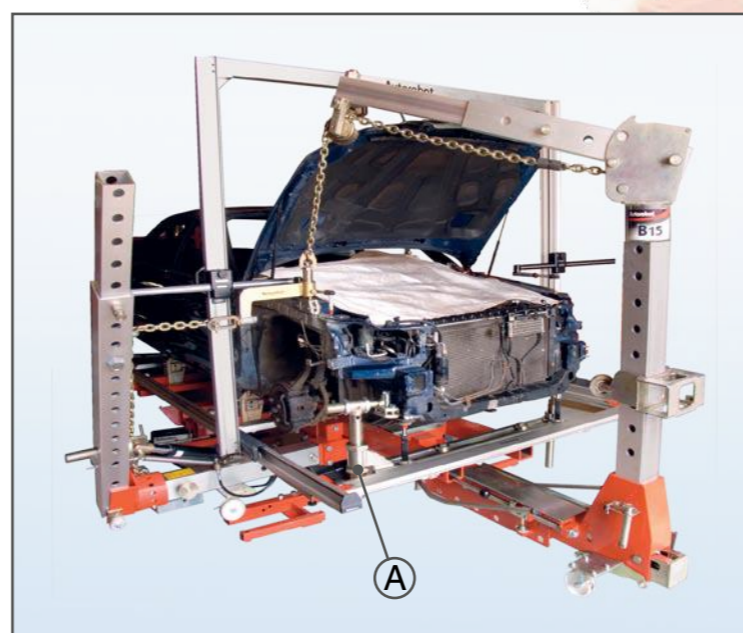

Total straightening control with Calipre's 300ELH/1 electronic/mechanical measuring system. Here, repair progress is tracked along the entire front of the vehicle, four points at a time: two points on the frame and two points at fender attachments. Initial repairs, such as frame straightening, can be held in place by a support jig (A) while body and suspension repairs are finished.



Pull accurately the first time, every time. Calipre's distinctive measuring system clearly displays necessary pull direction and travel length. Measuring reference points on Autorobot datasheets (some shown here in red) have all three length, width and height values. When all measurements have been pulled within accepted tolerance, with the help of the Calipre and datasheets, replacement parts fit accurately and the vehicle is restored to original condition.



An Calipre specialty. Datasheets have measuring points for fender mounting screws, as well. These points facilitate new-part positioning before welding.

Autorobot[®] Calipre

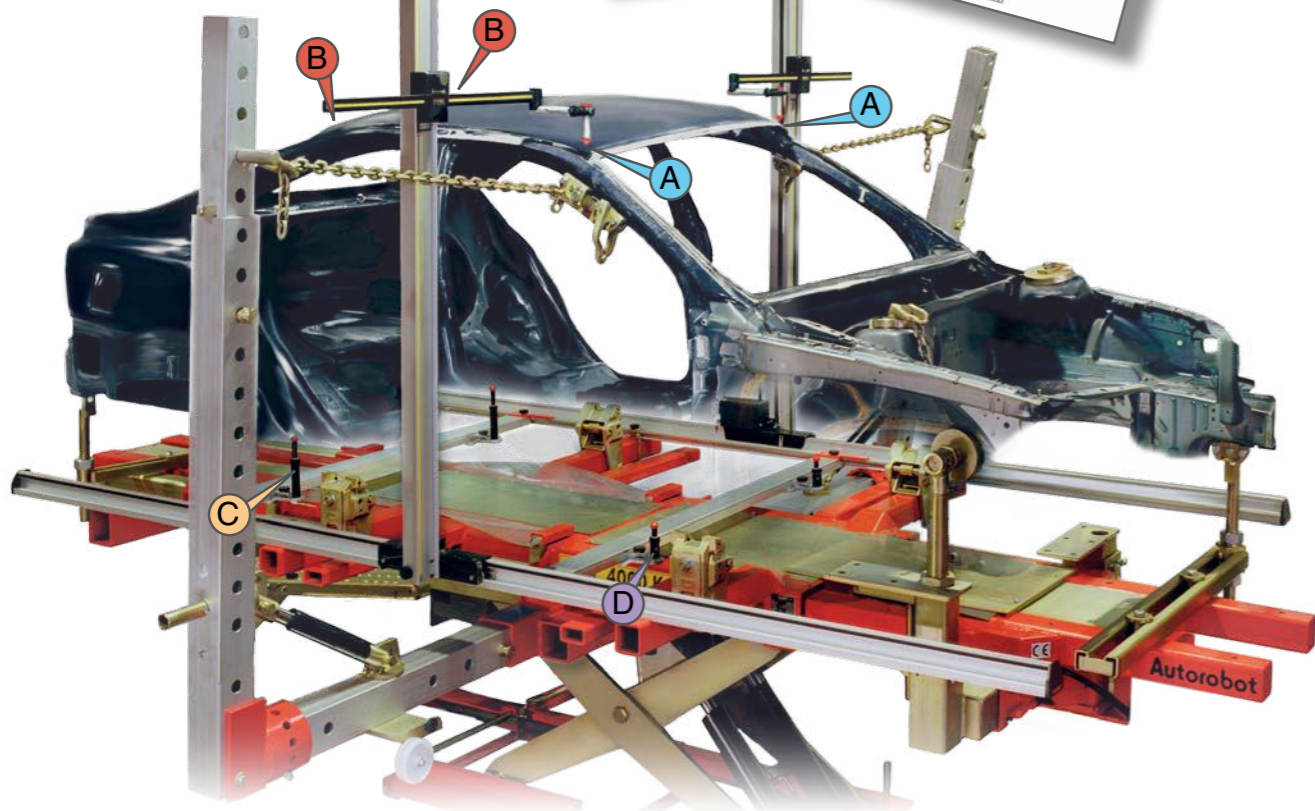
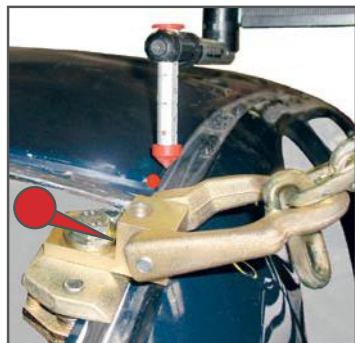

Nimble and innovative. What sets Autorobot Calipre apart is the patented measuring head. The superbly designed joints allow adjustment to reach all vehicle parts: chassis, upper body and inside structures. Smooth and easy movement from one point to another is simple, for example, from lower control arm to McPherson strut tower, without using any extra assemblies. Here, the rear spring upper mounting point is being measured.

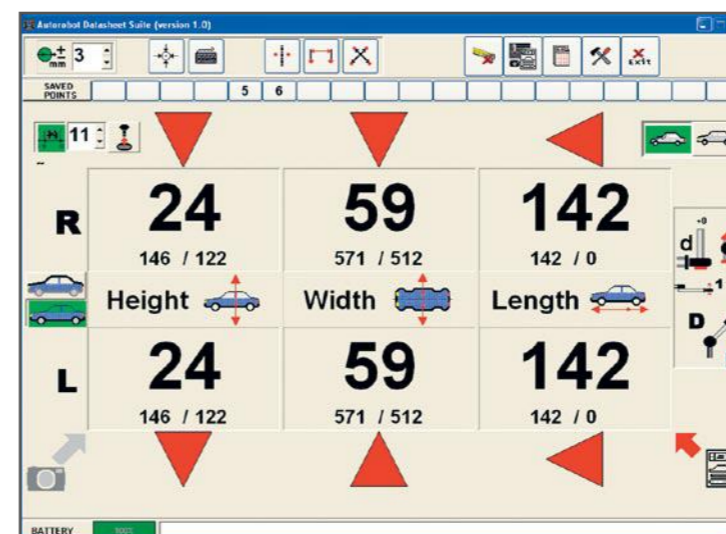
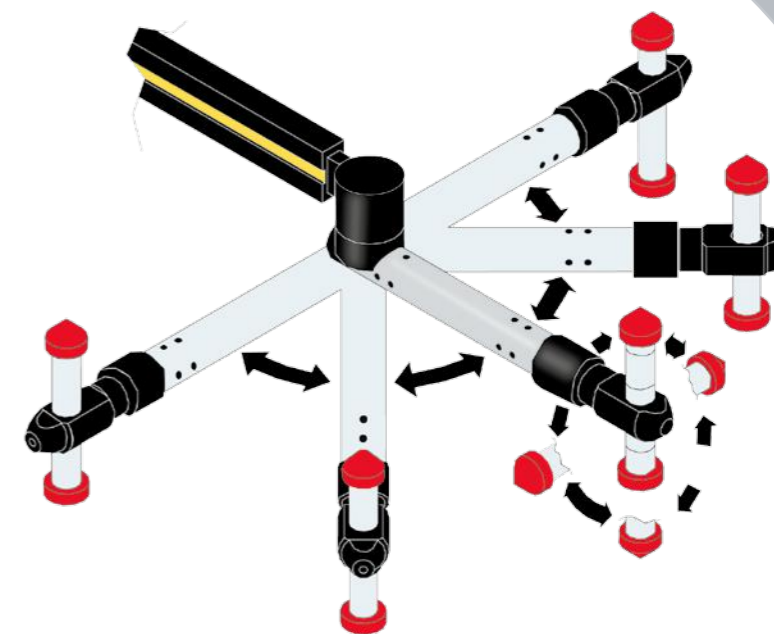

User friendly. Simple displays and large numbers make the screen easy to see and understand, even from a distance.

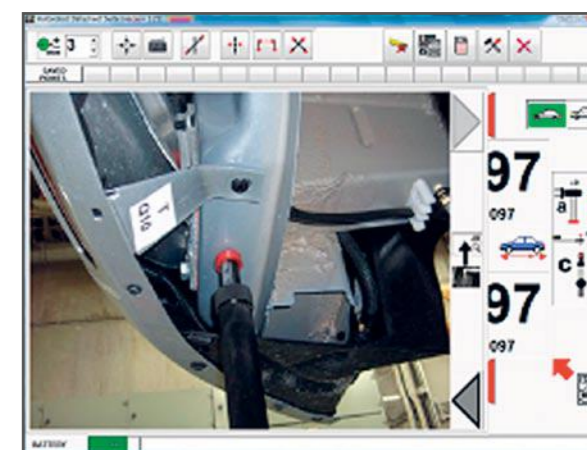

Real-world applications. View actual photographs to make it easier to locate datasheet measuring points. The photos can be enlarged on screen and printed, as well. When using automatic point search, the detail picture automatically gets updated when the measuring head position changes.



Computer-guided technology. Calipre shows three-dimensional values (length, width, height) of measuring points at both sides of vehicle simultaneously. Select the correct chassis/body position for the measuring head, click "save" and those measured points are stored in the computer. All points saved before and after repair can be printed out in a separate report. Calipre works with wireless WLAN technology; therefore it can be used with nearly any computer with a network adapter.



Superb documentation. Print reports showing extent of damage and verifying the accuracy of your repairs. These reports make a great impression on clients, insurance companies and vehicle inspectors.

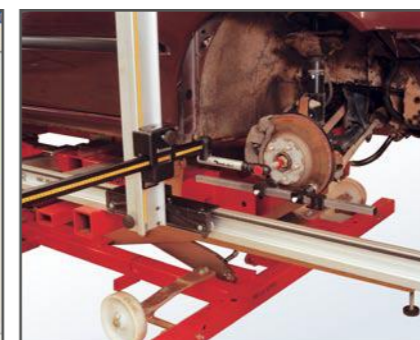

Suspension/steering repair. The 300ELH/3 package features an alignment bar for checking the condition of control arms and strut towers, among other things. Values from the sound side of the vehicle are compared to the damaged side. Axle distance measuring is easy, too. Please note: use of alignment bar needs mechanical system centering.

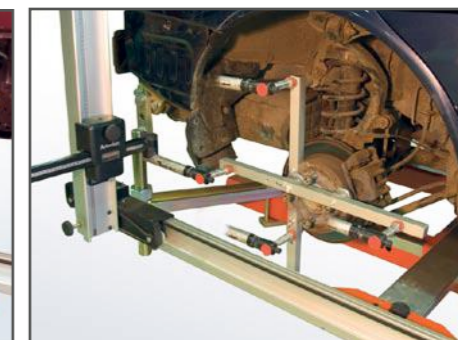

Autorobot[®] Calipre

Damage estimate and repair

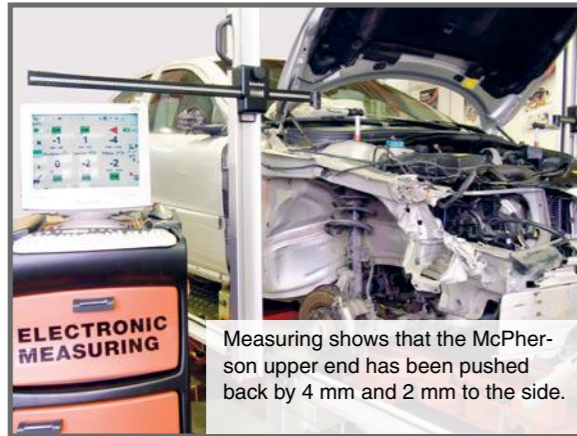

Measuring shows that the McPherson upper end has been pushed back by 4 mm and 2 mm to the side.

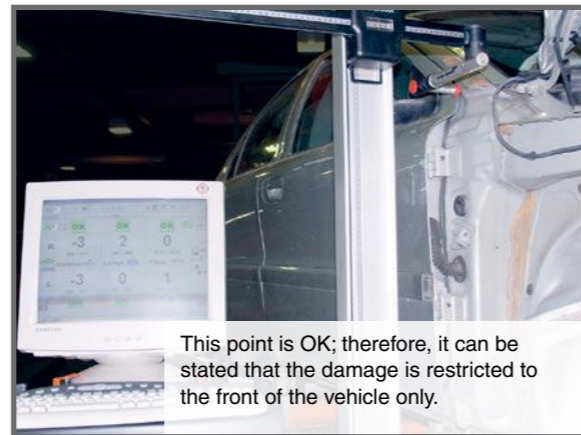

This point is OK; therefore, it can be stated that the damage is restricted to the front of the vehicle only.



Further checking verifies that the chassis is also within tolerance in other areas except the front.

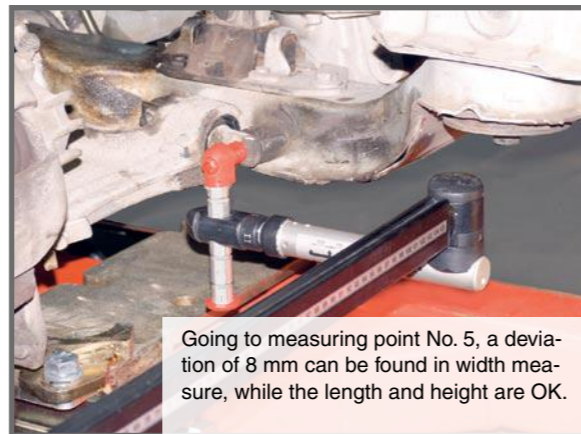

Going to measuring point No. 5, a deviation of 8 mm can be found in width measure, while the length and height are OK.



Auxiliary frame mounting points have deviations at both sides of the vehicle.

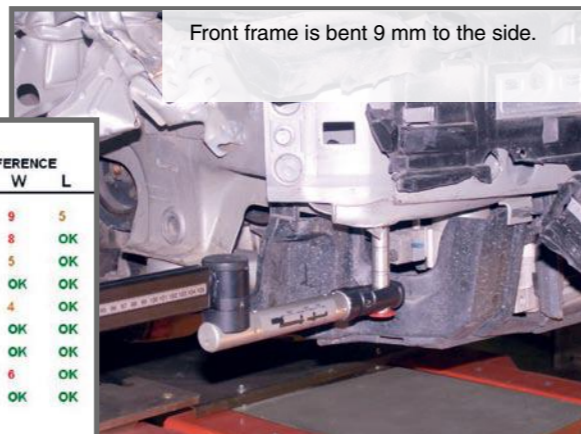

Front frame is bent 9 mm to the side.

UNDERBODY - BEFORE										
POINT #	TOLERANCE +/- mm	ACTUAL			DATASHEET			DIFFERENCE		
		H	W	L	H	W	L	H	W	L
2R	3	274	545	2838	276	554	2843	OK	9	5
5R	3	126	524	2563	123	532	2566	OK	8	OK
5L	3	125	537	2564	123	532	2566	OK	5	OK
6R	3	67	536	2319	66	534	2318	OK	OK	OK
6L	3	66	538	2321	66	534	2318	OK	4	OK
7R	3	45	434	1790	47	431	1793	OK	OK	OK
7L	3	45	431	1790	47	431	1793	OK	OK	OK
8R	3	44	526	1680	43	520	1680	OK	6	OK
8L	3	45	521	1682	43	520	1680	OK	OK	OK

After measuring analysis, sufficient information is available to conduct the actual repair – which direction to straighten and how far to extend the pull.

Straightening with guidance from the measuring device.

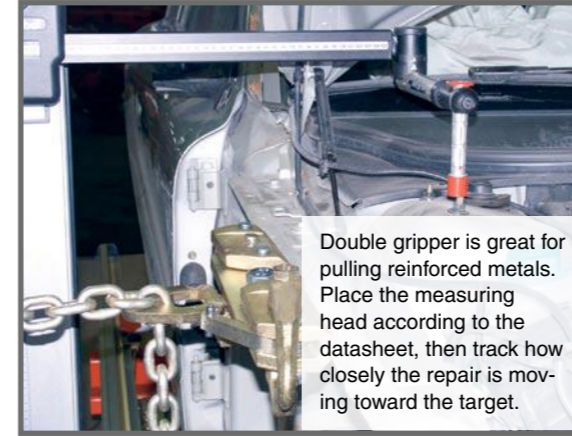

Double gripper is great for pulling reinforced metals. Place the measuring head according to the datasheet, then track how closely the repair is moving toward the target.

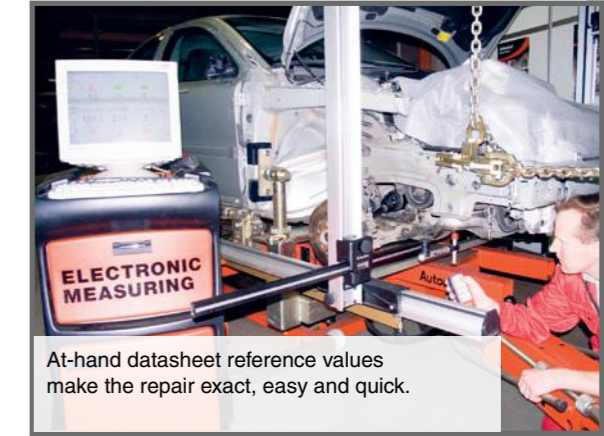

At-hand datasheet reference values make the repair exact, easy and quick.



UNDERBODY - AFTER										
POINT #	TOLERANCE +/- mm	ACTUAL			DATASHEET			DIFFERENCE		
		H	W	L	H	W	L	H	W	L
2R	3	274	554	2842	276	554	2843	OK	OK	OK
2L	3	278	556	2841	276	554	2843	OK	OK	OK
4R	3	262	521	2741	260	523	2743	OK	OK	OK
4L	3	261	526	2743	260	523	2743	OK	OK	OK
5R	3	124	533	2564	123	532	2566	OK	OK	OK
5L	3	121	534	2566	123	532	2566	OK	OK	OK
6R	3	65	534	2317	66	534	2318	OK	OK	OK
6L	3	67	533	2321	66	534	2318	OK	OK	OK
7R	3	48	433	1795	47	431	1793	OK	OK	OK
7L	3	48	433	1795	47	431	1793	OK	OK	OK
8R	3	41	522	1681	43	520	1680	OK	OK	OK
8L	3	42	522	1680	43	520	1680	OK	OK	OK
9R	3	55	420	1573	54	418	1574	OK	OK	OK
9L	3	55	420	1573	54	418	1574	OK	OK	OK

Straightening has been successful when all measuring points are within the tolerance of ± 3 mm as configured in the measuring software. A printed measuring document proves the top-quality results achieved by your body shop.

Sets

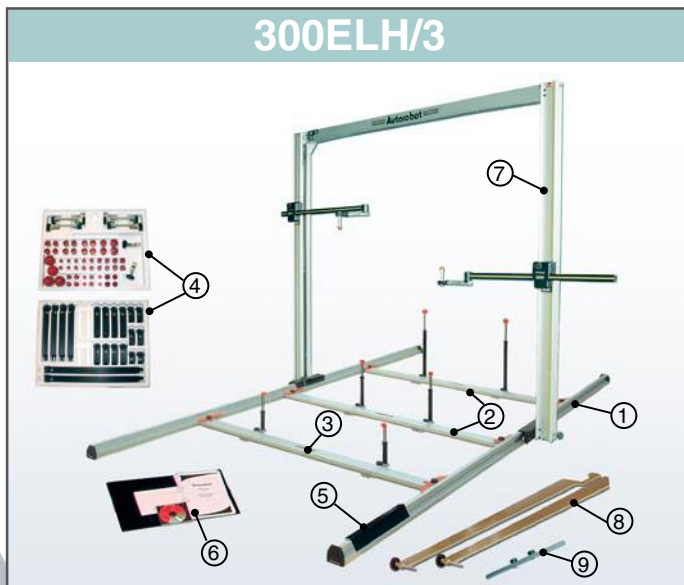
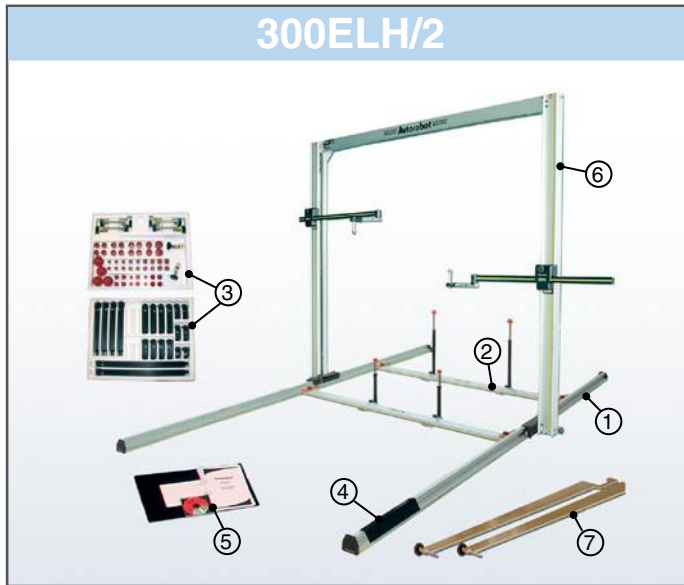
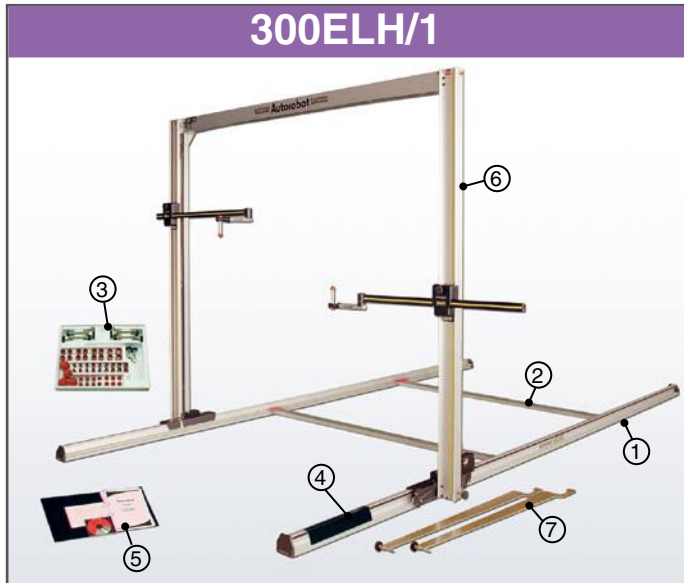

300ELH/1 Calibre Bronze		
300ELH/1 Electronic 3D measuring		Pc
Software centering		
1	Length beams	2
2	Distance bridge	2
3	Measuring instrument kit	1
4	Cover for length beam	1
5	CD-ROM datasheets	1
6	Electronic measuring arch	1
7	Holders for length beams	2

300ELH/2 Calibre Silver		
300ELH/2 Electronic/mechanical 3D measuring		Pc
Software and mechanical centering		
1	Length beams	2
2	Cross bridge, symmetrical	2
3	Mittavälinesarja	1
4	Cover for length beam	1
5	CD-ROM datasheets	1
6	Electronic measuring arch	1
7	Holders for length beams	2

300ELH/3 Calibre Gold		
300ELH/3 Electronic/mechanical 3D measuring		Pc
Software and mechanical centering		
1	Length beams	2
2	Cross bridge, symmetrical	2
3	Cross bridge, adjustable	1
4	Complete measuring instrument kit	1
5	Cover for length beam	1
6	CD-ROM datasheets	1
7	Electronic measuring arch	1
8	Holders for length beams	2
9	Axle alignment bar	1

Optional equipment



1	300EL+1C PC cabinet 300EL+2 PC and printer
2	731+1A Multi-purpose trolley