



VALVES

Product Range

Subscribe Now
Tescaglobal

“

Tesca is India's Exclusive Agent for Hydromine Projects & Marketing (Pty) Ltd, South Africa. In this Product Range we have High Quality Standards | LFC Range of High Pressure Isolating | Safety & Control Valves | Low Pressure Safety & Control Valves | Energy Dissipaters & Expansion Joints | HMP Range of Axial Surge Reduction Check Valves | Strainers | Hydraulic Coupling Range for Plain-Ended Shaft Column Piping | Air-Release | Ball | Butterfly | Diaphragm | Gate | Globe | Non-Return & Pinch Valves | HMPTE Ranges of Tapered Pipe Couplings | HMP Expansion Joints and Bellows | HMP Pressure Gauges | Pipe Fittings | Flanges and Fabrication | Spiral Wound and Ring Gaskets | HMP Heavy Duty Fire Hose Reels | Valve Reconditioning of Most Brands | Piping - Supply and Fabrication of Piping Material & Systems and others.

”



www.tescaglobal.com

+91-9829132777



6 May 2022

To: Tesca Technologies Pvt. Ltd.
Att: Mr. Ashutosh Agarwal – Director.
Re: Sale and Distribution in India

Hydromine™ Projects International, a Mauritius based company is the manufacturer of the New LFC™ product ranges.

This letter serves to confirm that Hydromine™ Projects International, is the sole manufacturer and distributor of the LFC™ product ranges.

Tesca Technologies Pvt. Ltd. is hereby appointed as an agent and distributor of the LFC™ range in India.

If you have any queries, please do not hesitate to call us at any time.

Yours truly,

H.J. de Lange
Chief Operations Officer

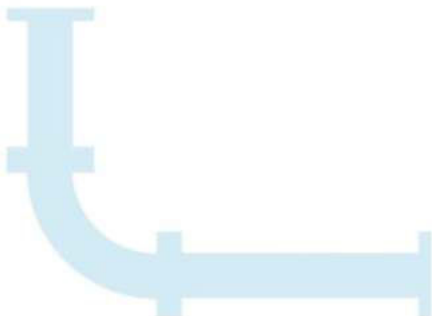



HMP™ Threaded Pipe Coupling

Overview:

The HMP™ Threaded Pipe Coupling is designed to suspend / hang high pressure pipes vertically in a bore hole or shaft. Where the pipe coupling must carry the weight of the entire pipe column below it, as well as the weight of the water / paste fill / back fill / slurry.

The HMP™ Threaded coupling is designed to take very little space. Installation is easy as the pipes screw into each other, then lowered down the bore hole or shaft. We are offering the service of Finite Element assessment to check that the column is not over stressed and that it is safe to operate.

The HMP™ Threaded coupling can be used in pumping or feeding of water, paste fill, back fill or slurry. The HMP™ Threaded couplings with the pipe column can be permanently installed by pouring concrete into the bore hole around the pipe column.

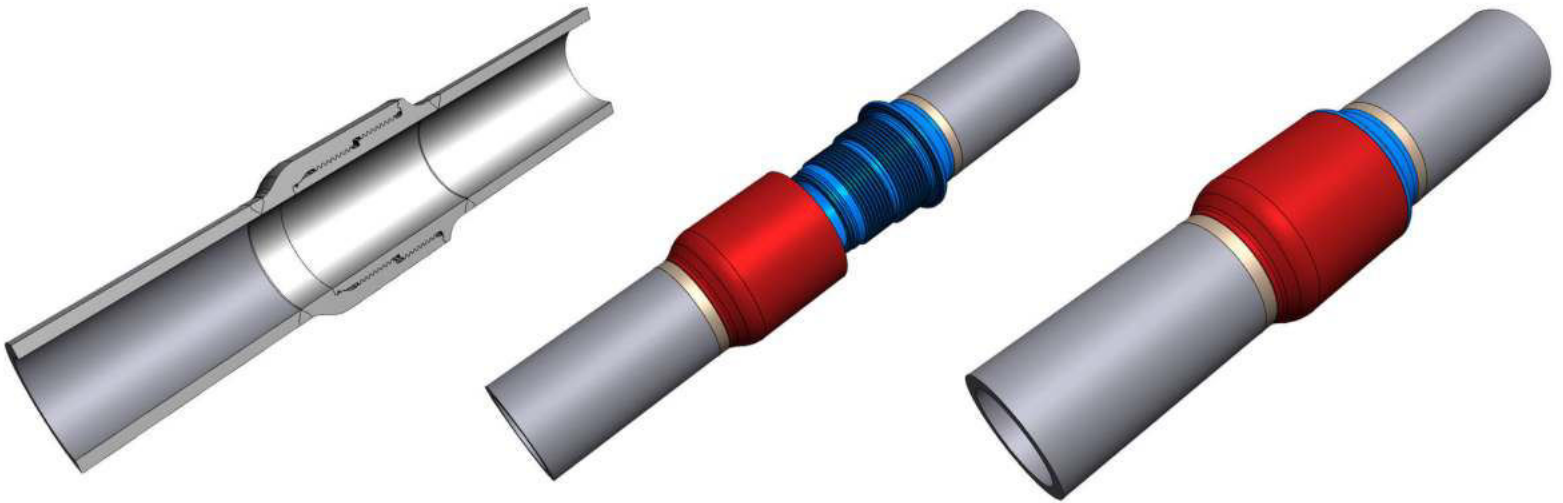

Materials Of Construction:

The HMP™ Threaded coupling can be manufactured in a wide range of carbon steel or stainless steel according to the client specification.

Design & Manufacturing Standards:

The HMP™ Threaded coupling has been designed in accordance with various international standards as set out below:

ASME Boilers and pressure vessels design code

ANSI B16.3 ANSI N278 .1

ANSI B16.34 ANSI B16.37

Available sizes: DN50 / 2" to DN250 / 10"

Pressure rating: up to 25MPa / 3 626 Psi

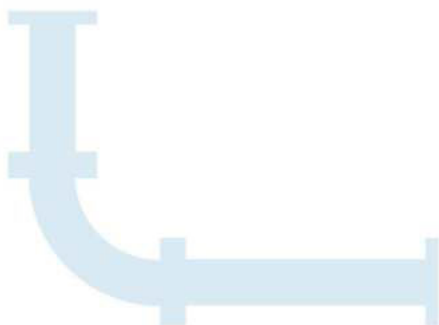



HMP™ _6A Axial Range Surge Reduction Check Valves

Overview:

The HMP™ _6A Axial Range Surge Reduction Check Valve stops reverse flow. It is commonly used in pump stations to stop the pump from running in reverse when the pump is stopped. The HMP™ _6A Axial Surge Reduction Check valves were designed to reduce the effects of water hammer when the check valve shuts down. Most conventional check valves on the market today only reduce flow in the last 30% of closure resulting in a rapid slamming action which creates water hammer. The HMP™ _6A Axial surge reduction check valves were developed to be more energy efficient with a better flow co-efficient (Cv) than most nozzle check valves on the market today. The nozzle check reduces the effects of water hammer but none of our competitors are energy efficient. In pumping systems, energy efficiency is crucial. Energy efficient valves will allow for a maximum amount of fluid to be pumped in the shortest amount of time that the pumping system can deliver. Whereas the time to pump the same amount of fluid with low energy efficiency valves will increase. Over time this will drastically increase the running cost of the pump station due to increased energy requirements as well as wear and tear on pumps and valves.

The HMP™ _6A Axial surge reduction check valve has been developed to present a robust, simple and cost effective high pressure (up to 25 MPa / 3 626 Psi) solution to fluid handling issues in any industrial sector.



Operating Conditions:

These valves are designed to operate in systems with relatively clean media like water or other liquids with a low percentage of suspended solids and chlorides. The valve's operating pH range is 2 – 14 pH.

Simplicity:

The HMP™ _6A Axial surge reduction check valve, disc is shaped to allow for a smoother flow path around it. The disc is carried by a shaft that can slide in a guide on the outlet side of the HMP™ _6A axial surge reduction valve body. On the outlet side of the surge reduction valve body guide, the guide is partly closed, creating a compartment. By closing the compartment partly, during a closing operation a vacuum is created inside the compartment of the guide. This prevents the disc from slamming shut and the HMP™ _6A Axial surge reduction check valve therefore closes in a controlled manner which drastically reduces the occurrence of water hammer.

By carrying the disc on a shaft, bush and guide, we increase the life of the HMP™ _6A Axial surge reduction check valve when compared to conventional check valves. Conventional check valves all have a hinge systems attached to the door / disc. These hinge systems are not very reliable as the hinges wear out and prevent the door /disc from closing to the correct position causing the check valve to leak and fail.

A spring is installed in the HMP™ _6A Axial surge reduction check valve to keep it in the closed position for commissioning. After the system is charged with pressure, the pressure acts on the moving wetted parts and forces the HMP™ _6A Axial surge reduction check valve closed and the spring serves no purpose. Once the pump starts or the pressure is higher from the inlet side of the HMP™ _6A Axial surge reduction check valve, the higher pressure pushes the check valve disk open.

Materials Of Construction:

Part Name	Material Specification
Body	BS3100 Grade A2 cast steel
Body Seat	F6 Stellite
Disc Seat #1	431 Stainless steel
Disc Seat # 2	UHMWPE
Guide	BS4360 Grade 43A
Spring	309 Stainless steel
Bush	Bronze LG2



HMP™ _6A Axial Range Surge Reduction Check Valves

Features:

- HMP™ _6A Axial Surge Reduction Check valve has a hard and soft seat. It can therefore withstand a little bit of dirt and is more reliable than conventional double and single door non return valves.
- It has no hinge mechanism, making it far more robust.

Low Maintenance Requirements:

The HMP™ _6A Axial surge reduction check valve only has one moving part making it very reliable. It is manufactured from stainless steel which increases reliability and durability. The HMP™ _6A Axial surge reduction check valve requires minimal maintenance which is made easy by removable guide configuration.

Dimensions:

Unit	Face To Face Dimensions							
	#600		#900		#600		#900	
	(mm)	(inch)	(mm)	(inch)	(mm)	(inch)	(mm)	(inch)
	F +/- 0,5				D +/- 0,2			
DN150 / 6"	136	5.35	159	6.26	265	10.43	288	11.34
DN200 / 8"	165	6.50	206	8.11	319	12.56	358	14.09
DN250 / 10"	213	8.39	241	9.49	399	15.71	434	17.09
DN300 / 12"	229	9.02	292	11.50	456	17.95	497	19.57

Design & Manufacturing Standards:

The HMP™ _6A Axial Range has been designed in accordance with various international standards as set out below:

ASME Boilers and pressure vessels design code

ANSI B16.3

ANSI B16.34

ANSI N278.1

ANSI B16.37

Available sizes: DN150 / 6" to DN300 / 12"

Pressure rating: up to 25MPa / 3 626 Psi

Can fit between ANSI B16.5 and BS4504 end connections.

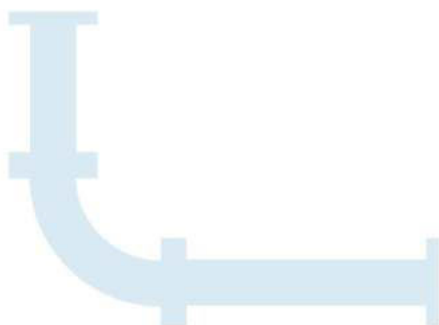



HMP™ _8 Range of Expansion Joints

Overview:

The HMP™ _8 Expansion joint is a custom designed piece of equipment that is designed to allow for contraction and expansion in vertical, inclined and horizontal installed piping.

There are two types of HMP™ _8 Expansion joints, the first with jacking bolt arrangement. The jacking bolt arrangement simplifies installation and prevents the expansion joint from pulling apart. The second type has no jacking bolt arrangement. Should this type of expansion joint be used, extra care needs to be taken in the design of the piping system in order to prevent to expansion joint from pulling apart. The HMP™ _8 Expansion joint can be produced in a double acting expansion joint with an anchor point in the middle.

Materials Of Construction:

Part Name	Material Specification
Stationary body #1	Casting - BS3100 Grade A2 with 309 S/Steel overlay
Stationary body #2	Hollow bar - ST52 with 309 S/Steel overlay
Stationary body #3	ASTM A105 with 309 S/Steel overlay
Stationary body #4	431 S/Steel or 309 S/Steel
Sliding body #1	Casting - BS3100 Grade A2 with 309 S/Steel overlay
Sliding body #2	Hollow bar - ST-52 with 309 S/Steel overlay
Sliding body #3	ASTM A105 with 309 S/Steel overlay
Sliding body #4	431 S/Steel or 309 S/Steel
Bolts	Grade 8.8, Hot dipped galvanized
Seals	Polyurethane
Flanges	ASTM A105
Bolts	Studs, grade 8.8, Hot dipped galvanized



Design & Manufacturing Standards:

The HMP _8™ Expansion Joint Range has been designed in accordance with various international standards as set out below:

ASME Boilers and pressure vessels design code

ANSI B16.3 ANSI N278.1

ANSI B16.34 ANSI B16.37

ANSI B16.5

Available sizes: DN50 / 2" to DN500 / 16"

Pressure rating: up to 25MPa / 3 626 psi

Available end connections: ANSI B16.5, BS4504, BS10, AS/NZS 4331.1 (ISO 7005-1) DIN, all makes of grooved or ring joint couplings, and other as per clients requirement.

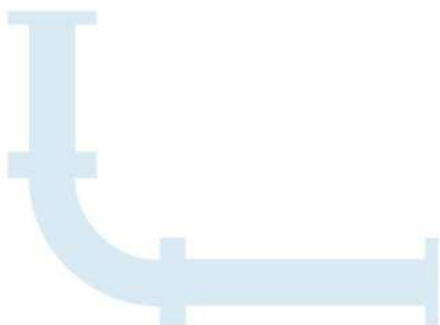



HMP™ _11A SANS 665 / BS 5163 PN16 Resilient Seal Gate Valves

Overview:

The HMP™ _11A PN16 Resilient Seal Gate valve were designed for easy seating. Not a lot of force is needed for the closing of the valve, due to the EDPM (rubber) encapsulated gate. This valve is widely used in low pressure applications below 1.6 MPa such as water treatment, water distribution, mining and power generations applications. The HMP™ _11A PN16 Resilient Seal Gate valve are manufactured with a bolted bonnet, flanged, face to face dimensions to SANS 665 / BS 5163 pattern, rising spindle and it's handwheel operated. The benefit of using rising spindle gate valve is that it can immediately be seen if the valve is in an open, closed or partly open position.

Low Operating Torque:

The HMP™ _11A PN16 Resilient Seal Gate Valve is quite easy opening and closing under pressure with a low operating torque.

Low Maintenance Requirement:

The HMP™ _11A PN16 Resilient Seal Gate valve does not have a lot of parts and does not require a lot maintenance.

Materials Of Construction:

No	Part Name	Specification
1	Handwheel	Cast iron FBE Coated
2	Bush nut	Brass
3	Spindle	410 S/Steel
4	Gland seal	NBR O-Ring
5	Cap Screws	Grade 12.9
6	Spindle nut	Brass
7	Body	SG Iron Fusion Bonded Epoxy coated or NBR Encapsulated on request
8	Gate	SG Iron NBR or EPDM Encapsulated
9	Handwheel nut	SG Iron
10	Drive bush	DZR
11	Bonnet / Yoke	SG Iron Fusion Bonded Epoxy coated
12	Cover Gland	SG Iron
13	O-Ring	Nitrile (Buna)
14	Bonnet O-Ring	Nitrile (Buna)

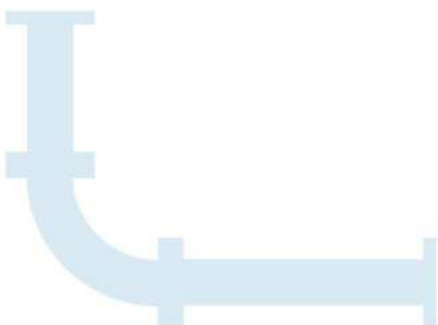
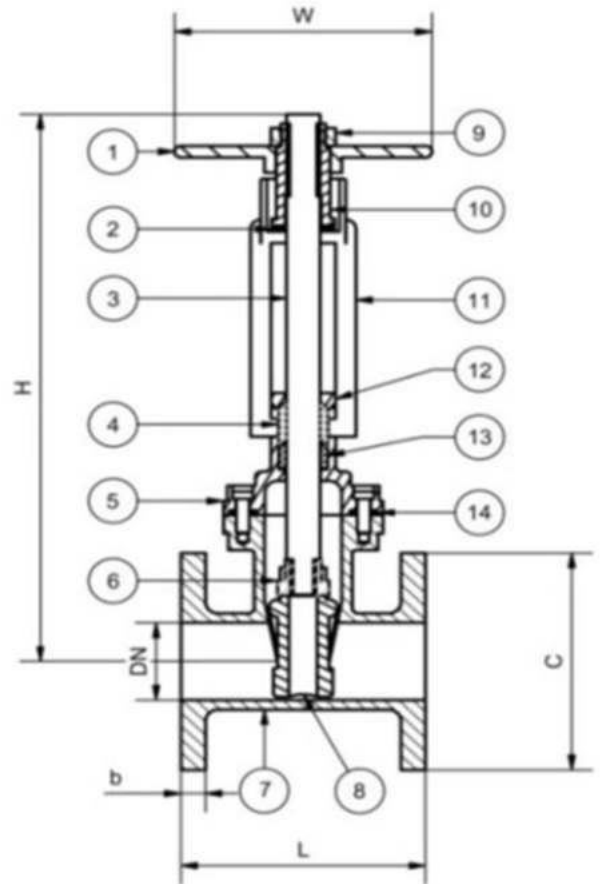



HMP™ _11A SANS 665 / BS 5163 PN16 Resilient Seal Gate Valves

Dimensions:

Valve Size		Face to face (L)		Centre to top of spindle in closed position (H)		Handwheel Ø (W)		Flange Ø (C)		Flange thickness (b)		Mass	
(DN)	(inch)	(mm)	(inch)	(mm)	(inch)	(mm)	(inch)	(mm)	(inch)	(mm)	(inch)	(kg)	(lbs)
50	2"	178	7,0	280	11,0	180	7,1	165	6,5	20	0,79	14	30,9
65	2 1/2"	190	7,5	320	12,6	180	7,1	185	7,3	20	0,79	14	30,9
80	3"	203	8,0	350	13,8	200	7,9	200	7,9	20	0,79	21	46,3
100	4"	229	9,0	405	15,9	250	9,8	220	8,7	22	0,87	24	52,9
125	5"	254	10,0	440	17,3	300	11,8	250	9,8	24	0,94	36	79,4
150	6"	267	10,5	490	19,3	300	11,8	285	11,2	24	0,94	42	92,6
200	8"	292	11,5	540	21,3	350	13,8	340	13,4	26	1,02	71	156,5
250	10"	330	13,0	720	28,3	400	15,7	405	15,9	30	1,18	101	222,7
300	12"	356	14,0	860	33,9	540	21,3	460	18,1	32	1,26	139	306,4
350	14"	381	15,0	975	38,4	600	23,6	520	20,5	34	1,34	201	443,1
400	16"	406	16,0	1140	44,9	600	23,6	580	22,8	36	1,42	247	544,5
450	18"	432	17,0	1300	51,2	600	23,6	640	25,2	36	1,42	360	793,7
500	20"	457	18,0	1445	56,9	600	23,6	715	28,1	36	1,42	690	1521,2
600	24"	508	20,0	1235	48,6	600	23,6	840	33,1	40	1,57	830	1829,8

Design & Manufacturing Standards:

The HMP™ _11A PN16 Resilient Seal Gate Valve are designed in accordance with various international standards as set out below:

SANS 665
BS 5163

Flange drilling can be drilled to the following standards:

ANSI B16.1 Class 125	BS 4504 / D.I.N. T6
ANSI B16.5 Class 150	BS 4504 / D.I.N. T10
SANS 1123 T600	BS 4504 / D.I.N. T16
SANS 1123 T1000	BS 10 / AS2129
SANS 1123 T1600	Table D BS 10 / AS2129
EN1092 PN10 and PN16	Table E JIS B2239 5K and 10K

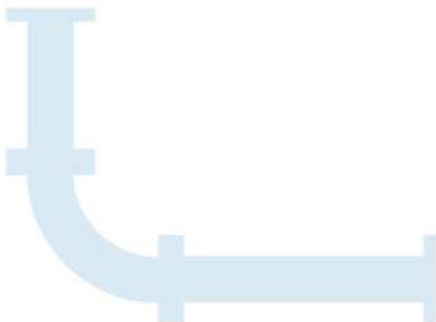



HMP™ _11C API 600 Wedge Gate Valves

Overview:

The HMP™ _11C API 600 Wedge Gate valve are designed in accordance with API 600. It is suitable to be used in temperatures up to 600 °C / 1112 °F. The valve are manufactured with a bolted bonnet, flanged or butt welded, rising spindle and handwheel operated. These valve are widely used in water treatment, water distribution, mining and power generations applications. The benefit of using rising spindle gate valves are that it can immediately be seen if the valve is in an open, closed or partly open position.

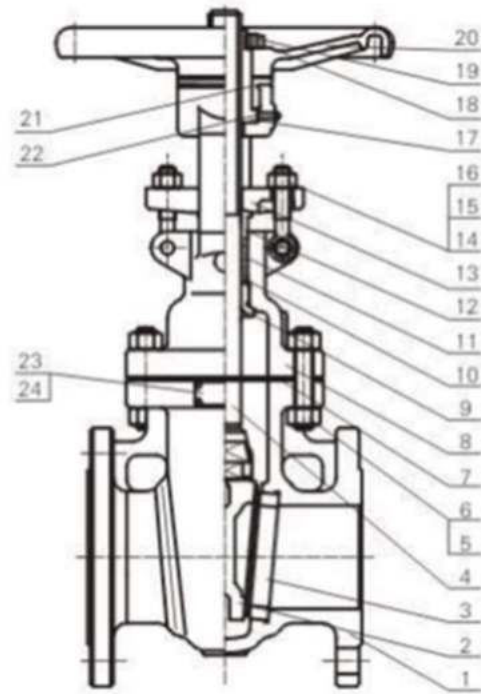

Materials Of Construction:

No	Part name	WCB	C5	WC6	CF8	CF8M
1	Body	A216 WCB	A217 C5	A217 WC6	A351 CF8	A351 CF8M
2	Wedge gate	A216 WCB / Stellite 6	A217 C5 / Stellite 6	A217 WC6 / Stellite 6	A351 CF8	A351 CF8M
3	Seat	A105 / Stellite 6	A182 F11 / Stellite 6	A182 F11 / Stellite 6	A182 F304 / Stellite 6	A182 F316 / Stellite 6
4	Stem	A182 F6a	A182 F6a	A182 F6a	A182 F304	A182 F316
5	Bolt	A193 B7	A193 B7	A193 B7	A193 B8	A193 B8M
6	Nut	A194 2H	A194 2H	A194 2H	A194 8	A194 8M
7	Gasket 150lbs	304 / Flexible graphite	304 / Flexible graphite	304 / Flexible graphite	304 / Flexible graphite	316 / Flexible graphite
	Gasket 1300lbs	304 / Flexible graphite	304 / Flexible graphite	304 / Flexible graphite	304 / Flexible graphite	Spiral wound
	Gasket ≥600lbs	F304	F304	F304	F304	Spiral wound
8	Bonnet	A216 WCB	A217 C5	A217 WC6	A351 CF8	A351 CF8M
9	Backseat	A182 F6a	A182 F6a	A182 F6a	A182 F6a	A182 F316
10	Packing	304 / Flexible graphite	304 / Flexible graphite	304 / Flexible graphite	304 / Flexible graphite	Pilar 6610 / 6528
11	Distance ring	A182 F6a	A182 F6a	A182 F6a	A182 F304	A182 F316
12	Packing gland	A182 F6a	A182 F6a	A182 F6a	A182 F304	A182 F316
13	Packing plate	A216 WCB	A216 WCB	A216 WCB	A351 CF8	A351 CF8M
14	Eye bolt	A193 B7	A193 B7	A193 B7	A193 B8	A193 B8
15	Nut	A194 2H	A194 2H	A194 2H	A194 8	A194 8
16	Pin	1035	1035	1035	SS 304	SS 304
17	Driving bush	A439 Type D2	A439 Type D2	A439 Type D2	A439 Type D2	A439 Type D2
18	Locking nut	1035	1035	1035	1035	1035
19	Locking screw	1035	1035	1035	1035	1035
20	Handwheel	Cast Iron	Cast Iron	Cast Iron	Cast Iron	Cast Iron
21	Bearing gland	1035	1035	1035	1035	1035
22	Oil nipple	Zink plated steel	Zink plated steel	Zink plated steel	SS 304	SS 304
23	Nameplate	SS 304	SS 304	SS 304	SS 304	SS 304
24	Rivet	SS 304	SS 304	SS 304	SS 304	SS 304
Seat temperature rating (°C)		-29 °C to 425 °C	-29 °C to 650 °C	-29 °C to 595 °C	-29 °C to 600 °C	-29 °C to 600 °C
Seat temperature rating (°F)		-20 °F to 797 °F	-20 °F to 1202 °F	-20 °F to 1103 °F	-20 °F to 1112 °F	-20 °F to 1112 °F



HMP™ _11C API 600 Wedge Gate Valves

Dimensions:

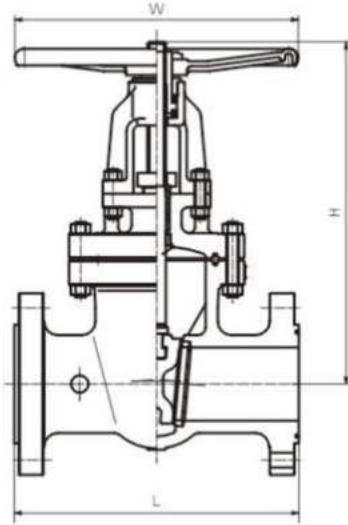

Valve Size		Face to Face (L)				Centre to top		Handwheel Ø		Mass			
		Flanged		Buttwelded		H (Open)		W		Flanged		Buttwelded	
(DN)	(inch)	(mm)	(inch)	(mm)	(inch)	(mm)	(inch)	(mm)	(inch)	(kg)	(lbs)	(kg)	(lbs)
50	2"	178	7,0	216	8,5	341	13,4	200	7,9	20	44	19	41,89
65	2 1/2"	190	7,5	241	9,5	371	14,6	200	7,9	30	66	28	61,73
80	3"	203	8,0	283	11,1	402	15,8	250	9,8	33	73	30	66,14
100	4"	229	9,0	305	12,0	472	18,6	280	11,0	49	108	45	99,21
125	5"	254	10,0	381	15,0	530	20,9	300	11,8	60	132	65	143,30
150	6"	267	10,5	403	15,9	587	23,1	300	11,8	75	165	70	154,32
200	8"	292	11,5	419	16,5	783	30,8	350	13,8	120	265	110	242,51
250	10"	330	13,0	457	18,0	904	35,6	400	15,7	205	452	194	427,70
300	12"	356	14,0	502	19,8	1047	41,2	450	17,7	290	639	278	612,88
350	14"	381	15,0	572	22,5	1172	46,1	500	19,7	400	882	375	826,73
400	16"	406	16,0	610	24,0	1297	51,1	600	23,6	511	1127	465	1025,15
450	18"	432	17,0	660	26,0	1433	56,4	680	26,8	650	1433	538	1186,09
500	20"	457	18,0	711	28,0	1590	62,6	750	29,5	789	1739	715	1576,30
600	24"	508	20,0	813	32,0	1898	74,7	800	31,5	1200	2646	1050	2314,85
650	26"	559	22,0	864	34,0	2000	78,7			1500	3307		
700	28"	610	24,0	914	36,0	2050	80,7			1800	3968		
750	30"	610	24,0	914	36,0	2330	91,7			2560	5644		
800	32"	660	26,0	965	38,0	2533	99,7			3060	6746		
850	34"	700	27,6	1000	39,4	2698	106,2			3320	7319		
900	36"	711	28,0	1060	41,7	2800	110,2			3500	7716		
950	38"	736	29,0	1041	41,0	3960	155,9			3850	8488		
1000	40"	762	30,0	1067	42,0	4030	158,7			4100	9039		
1050	42"	787	31,0	1118	44,0	4229	166,5			6050	13338		
1150	46"	850	33,5	1092	43,0	4744	186,8			7300	16094		
1200	48"	914	36,0	1118	44,0	4821	189,8			7550	16645		
1250	50"	950	37,4			5183	204,1			8000	17637		
1350	54"	1016	40,0			5501	216,6			8600	18960		
1400	56"	1041	41,0			5791	228,0			9200	20283		
1500	60"	1067	42,0			6066	238,8			12700	27999		
1600	64"	1118	44,0			6591	259,5			13800	30424		

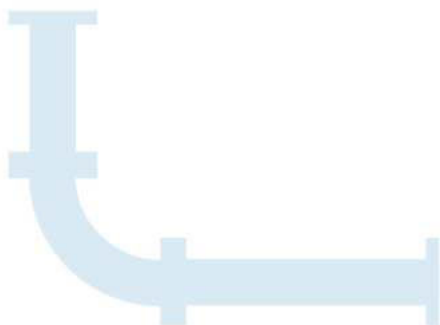



HMP™ _11C API 600 Wedge Gate Valves

Dimensions:

Valve Size		300lbs											
		Face to Face (L)				Centre to top		Handwheel Ø		Mass			
		Flanged		Buttwelded		H (Open)		W		Flanged		Buttwelded	
(DN)	(inch)	(mm)	(inch)	(mm)	(inch)	(mm)	(inch)	(mm)	(inch)	(kg)	(lbs)	(kg)	(lbs)
50	2"	216	8,5	216	8,5	345	13,6	200	7,9	24	53	21	46
65	2 1/2"	241	9,5	241	9,5	376	14,8	200	7,9	36	79	25	55
80	3"	283	11,1	283	11,1	407	16,0	250	9,8	47	104	41	90
100	4"	305	12,0	305	12,0	478	18,8	300	11,8	69	152	62	137
125	5"	381	15,0	381	15,0	535	21,1	300	11,8	89	196	80	176
150	6"	403	15,9	403	15,9	618	24,3	350	13,8	123	271	111	245
200	8"	419	16,5	419	16,5	765	30,1	400	15,7	196	432	188	414
250	10"	457	18,0	457	18,0	929	36,6	450	17,7	333	734	274	604
300	12"	502	19,8	502	19,8	1094	43,1	500	19,7	440	970	408	899
350	14"	762	30,0	762	30,0	1188	46,8	550	21,7	710	1565	532	1173
400	16"	838	33,0	838	33,0	1329	52,3	680	26,8	950	2094	730	1609
450	18"	914	36,0	914	36,0	1455	57,3	750	29,5	1405	3097	918	2024
500	20"	991	39,0	991	39,0	1860	73,2	920	36,2	1720	3792	1259	2776
600	24"	1143	45,0	1143	45,0	2030	79,9			2770	6107	1952	4303
650	26"	1245	49,0	1245	49,0	2400	94,5			2900	6393	2262	4987
700	28"	1346	53,0	1346	53,0	2800	110,2			3312	7302	3525	7771
750	30"	1397	55,0	1397	55,0	3150	124,0			4100	9039	3672	8095
800	32"	1524	60,0	1524	60,0	3300	129,9			5200	11464	4266	9405
850	34"	1626	64,0	1626	64,0	3750	147,6			5600	12346	4866	10728
900	36"	1727	68,0	1727	68,0	4250	167,3			6700	14771	5669	12498
1000	40"	1930	76,0	1930	76,0	4550	179,1			7400	16314	7020	15476
1050	42"	1930	76,0	1930	76,0	4550	179,1			7700	16976	7200	15873
1100	44"	2032	80,0	2032	80,0	4750	187,0			10600	23369	9900	21826
1150	46"	2032	80,0	2032	80,0	4820	189,8			10900	24030	10100	22267
1200	48"	2235	88,0	2235	88,0	5250	206,7			13400	29542	12600	27778
1350	54"	2286	90,0	2286	90,0	5900	232,3			18000	39683	16900	37258

Valve Size		600lbs											
		Face to Face (L)				Centre to top		Handwheel Ø		Mass			
		Flanged		Buttwelded		H (Open)		W		Flanged		Buttwelded	
(DN)	(inch)	(mm)	(inch)	(mm)	(inch)	(mm)	(inch)	(mm)	(inch)	(kg)	(lbs)	(kg)	(lbs)
50	2"	292	11,5	292	11,5	377	14,8	200	7,9	39	86	27	60
65	2 1/2"	330	13,0	330	13,0	443	17,4	250	9,8	52	115	40	88
80	3"	356	14,0	356	14,0	465	18,3	280	11,0	88	194	59	130
100	4"	432	17,0	432	17,0	525	20,7	300	11,8	114	251	102	225
125	5"	508	20,0	508	20,0	610	24,0	400	15,7	204	450	190	419
150	6"	559	22,0	559	22,0	672	26,5	450	17,7	285	628	263	580
200	8"	660	26,0	660	26,0	820	32,3	500	19,7	413	911	329	725
250	10"	787	31,0	787	31,0	983	38,7	680	26,8	650	1433	520	1146
300	12"	838	33,0	838	33,0	1120	44,1	750	29,5	800	1764	750	1653
350	14"	889	35,0	889	35,0	1283	50,5	800	31,5	1140	2513	1000	2205
400	16"	991	39,0	991	39,0	1429	56,3			1700	3748	1350	2976
450	18"	1092	43,0	1092	43,0	1572	61,9			2268	5000	1820	4012
500	20"	1194	47,0	1194	47,0	1757	69,2			2850	6283	2550	5622
600	24"	1397	55,0	1397	55,0	1985	78,1			3500	7716	3000	6614
650	26"	1448	57,0	1448	57,0	2100	82,7			3900	8598	3500	7716
700	28"	1549	61,0	1549	61,0	2230	87,8			4200	9259	3700	8157
750	30"	1651	65,0	1651	65,0	2475	97,4			5400	11905	4500	9921
800	32"	1778	70,0	1778	70,0	2300	90,6			8500	18739	7600	16755
850	34"	1930	76,0	1930	76,0	2700	106,3			9100	20062	8200	18078
900	36"	2083	82,0	2083	82,0	2950	116,1			10800	23810	9900	21826
950	38"	2184	86,0	2184	86,0	3100	122,0			12100	26676	11100	24471
1000	40"	2286	90,0	2286	90,0	4500	177,2			15000	33069	14100	31085
1100	44"	2490	98,0	2490	98,0	4700	185,0			19300	42549	18100	39904
1250	50"	2794	110,0	2794	110,0	5500	216,5			26700	58863	25200	55556

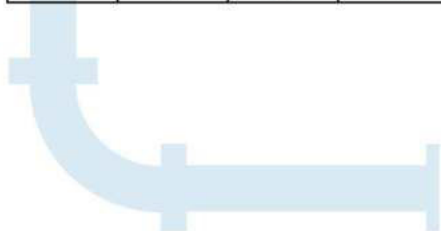



HMP™ _11C API 600 Wedge Gate Valves

Dimensions:

Valve Size		Face to Face (L)				Centre to top		Handwheel Ø		Mass			
		Flanged		Buttwelded		H (Open)		W		Flanged		Buttwelded	
(DN)	(inch)	(mm)	(inch)	(mm)	(inch)	(mm)	(inch)	(mm)	(inch)	(kg)	(lbs)	(kg)	(lbs)
50	2"	368	14,5	368	14,5	445	17,5	300	11,8	72	159	64	141
65	2 1/2"	419	16,5	419	16,5	480	18,9	300	11,8	101	223	94	207
80	3"	381	15,0	381	15,0	514	20,2	350	13,8	130	287	109	240
100	4"	457	18,0	457	18,0	614	24,2	400	15,7	197	434	159	351
125	5"	559	22,0	559	22,0	730	28,7	500	19,7	285	628	250	551
150	6"	610	24,0	610	24,0	834	32,8	600	23,6	404	891	374	825
200	8"	737	29,0	737	29,0	875	34,4	600	23,6	650	1433	611	1347
250	10"	838	33,0	838	33,0	1040	40,9	700	27,6	1376	3034	1180	2601
300	12"	965	38,0	965	38,0	1150	45,3	800	31,5	1710	3770	1493	3291
350	14"	1029	40,5	1029	40,5	1360	53,5			2100	4630	1892	4171
400	16"	1130	44,5	1130	44,5	1520	59,8			2920	6437	2650	5842
450	18"	1219	48,0	1219	48,0	1830	72,0			5000	11023	4500	9921
500	20"	1321	52,0	1321	52,0	2100	82,7			5720	12610	5240	11552
600	24"	1549	61,0	1549	61,0	2610	102,8			8200	18078	7100	15653

Valve Size		Face to Face (L)				Centre to top		Handwheel Ø		Mass			
		Flanged		Buttwelded		H (Open)		W		Flanged		Buttwelded	
(DN)	(inch)	(mm)	(inch)	(mm)	(inch)	(mm)	(inch)	(mm)	(inch)	(kg)	(lbs)	(kg)	(lbs)
50	2"	368	14,5	368	14,5	462	18,2	300	11,8	85	187	68	150
65	2 1/2"	419	16,5	419	16,5	512	20,2	350	13,8	130	287	122	269
80	3"	470	18,5	470	18,5	550	21,7	400	15,7	170	375	116	256
100	4"	546	21,5	546	21,5	752	29,6	550	21,7	305	672	195	430
125	5"	673	26,5	673	26,5	927	36,5	550	21,7	590	1301	478	1054
150	6"	705	27,8	705	27,8	1120	44,1	600	23,6	664	1464	510	1124
200	8"	832	32,8	832	32,8	1390	54,7	700	27,6	1100	2425	839	1850
250	10"	991	39,0	991	39,0	1524	60,0	800	31,5	1600	3527	1180	2601
300	12"	1130	44,5	1130	44,5	1850	72,8			2980	6570	2580	5688
350	14"	1257	49,5	1257	49,5	2180	85,8			2700	5952	2120	4674
400	16"	1384	54,5	1384	54,5	2210	87,0			3500	7716	2987	6585

Valve Size		Face to Face (L)				Centre to top		Handwheel Ø		Mass			
		Flanged		Buttwelded		H (Open)		W		Flanged		Buttwelded	
(DN)	(inch)	(mm)	(inch)	(mm)	(inch)	(mm)	(inch)	(mm)	(inch)	(kg)	(lbs)	(kg)	(lbs)
50	2"	451	17,8	451	17,8	520	20,5	300	11,8				
65	2 1/2"	508	20,0	508	20,0	630	24,8	350	13,8				
80	3"	578	22,8	578	22,8	730	28,7	400	15,7				
100	4"	673	26,5	673	26,5	880	34,6	550	21,7				
125	5"	794	31,3	794	31,3	1020	40,2	600	23,6				
150	6"	914	36,0	914	36,0	1120	44,1	700	27,6				
200	8"	1022	40,2	1022	40,2	1500	59,1	800	31,5				
250	10"	1270	50,0	1270	50,0	1610	63,4						
300	12"	1422	56,0	1422	56,0	1900	74,8						

Design & Manufacturing Standards:

The HMP™ _11C are designed in accordance with various international standards as set out below:
ASME Boilers and pressure vessels design code

- API 600 ANSI B16.25
- ANSI B16.10 ANSI B16.3
- ANSI B16.34 ANSI B16.37
- ANSI B16.5 ANSI N278.1

Flange drilling can also be drilled on request to BS4505, D.I.N, BS10, AS2129, AS/NZS 4331.1 (ISO 7005-1), JIS B2239, EN1092 and SANS 1123 standards.



HMP™_12A PN10 / 16 Concentric Wafer Type Butterfly Valves With Stainless steel discs

Overview:

The HMP™_12A PN10 / 16 Concentric Wafer Type Butterfly Valves with Stainless steel discs are widely used in low pressure applications below 1.6 MPa such as water treatment, water distribution, mining, food and beverage, pulp and paper, chemical, and power plants. With its EDPM cartridge type seat (rubber liner) and streamlined disc, not a lot of force is needed for the closing of the valve. The main benefits of using the HMP™_12A PN16 Wafer Type Butterfly Valve is that it is very cost effective, small, easy to install, all parts in contact with the line fluid are corrosion resistant, dirt are scaped from seat during closing operation and no gaskets are required to seal flange connections.

DN50 / 2" to DN600 / 24":

Lever Operated



Gearbox Operated



DN700 / 28" to DN2000 / 80":





HMP™ 12A PN10 / 16 Concentric Wafer Type Butterfly Valves With Stainless steel discs

Features:

- Media: Potable water, service water, wastewater, seawater, HVAC, Air, Vapour, food, pharmaceutical, oils, acid and Alkalis.
- Temperature range: -37 °C to + 150 °C / 35 °F to + 302 °F (depending on pressure, medium and material).
- Diameter nominal: DN50 – DN2000 / 2" – 80"
- Operating pressure: 1.6Mpa / 232 psi for DN50-DN600 / 2"-24", 1Mpa / 145 psi for DN350-DN2000 / 14"-80".
- Operation: Hand lever, gearbox, pneumatic actuator, electric actuator or hydraulic actuator.
- Mounting flange design: ISO5211
- Safety feature: Stem anti-blowout design.
- Connection: Wafer, lug design enables the valve to be installed between various flange standards and no gaskets are required to seal flange connections.

Materials Of Construction:

No	Part name	Specification	Specification - Optional					
			Ductile iron	Aluminium	CF8	CF8M	Carbon steel	
1	Body	Cast Iron						
2	Disc	CF8	CF8M					
3	Shaft	SS 410	SS 304	SS 316	Monel			
4	Bush	Lubricated bronze	PTFE	Fibreglass backed PTFE				
5	Key	Key steel						
6	O-Ring	Nitrile (Buna)						
9	Lever	Cast Iron						
10	Gearbox housing	Cast Iron						
12	Handwheel	Cast Iron						
13	Seat	EDPM	Bona-N	PTFE	Neoprene	NBR	Hypalon	VITON
Seat temperature rating (°C)		-25 °C to 95 °C	-37 °C to 121 °C	-10 °C to 150 °C	-7 °C to 93 °C	-12 °C to 82 °C	-18 °C to 135 °C	-23 °C to 150 °C
Seat temperature rating (°F)		-13 F to 203 F	-35 F to 250 F	14 F to 302 F	19 F to 199 F	10 F to 180 F	0 F to 275 F	-9 F to 302 F

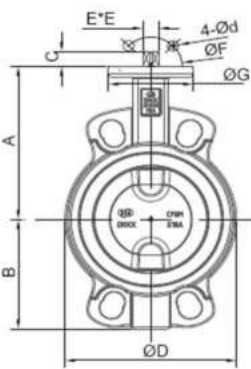

DN50-DN300

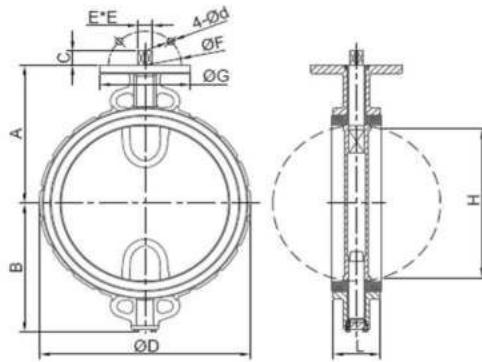

DN350-DN600

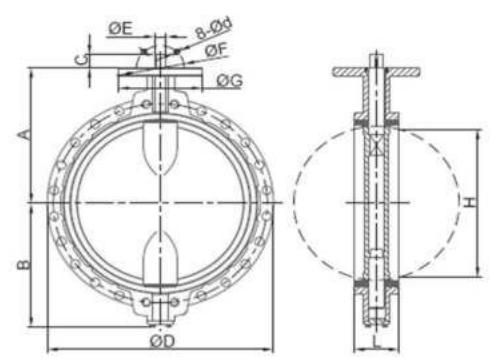

DN700-DN2000

Maximum Torque Requirement:

Valve Size		PN10	145 psi	PN16	232 psi	Valve Size		PN10	145 psi	PN16	232 psi
(DN)	(inch)	(N.m)	(ft.lbf)	(N.m)	(ft.lbf)	(DN)	(inch)	(N.m)	(ft.lbf)	(N.m)	(ft.lbf)
50	2"	9,5	7,0	12,7	9,4	250	10"	164	121,0	262	193,2
65	2 1/2"	12	8,9	15	11,1	300	12"	203	149,7	264	194,7
80	3"	16	11,8	21	15,5	350	14"	232	171,1	562	414,5
100	4"	23	17,0	30	22,1	400	16"	622	458,8	870	641,7
125	5"	41	30,2	53	39,1	450	18"	829	611,4	1161	856,3
150	6"	53	39,1	59	43,5	500	20"	1036	764,1	1451	1070,2
200	8"	68	50,2	100	73,8	600	24"	1314	969,2	1840	1357,1



HMP™ _12A PN10 / 16 Concentric Wafer Type Butterfly Valves With Stainless steel discs

Dimensions:

Valve Size		Face to face(L)		Centre to top flange (A)		Centre to bottom (B)		Top flange to top of shaft (C)		Diameter of body (D)		Diameter of shaft (E)		PCD (Ø)of mounting flange (F)		Mounting flange hole diameter (d), number of holes & ISO 5211 flange type (flg type)				Diameter of disk (G or H)		Mass	
(DN)	(inch)	(mm)	(inch)	(mm)	(inch)	(mm)	(inch)	(mm)	(inch)	(mm)	(inch)	(mm)	(inch)	(mm)	(inch)	(mm)	(inch)	hole no	(flg type)	(mm)	(inch)	(kg)	(lbs)
50	2"	42	1,65	161	6,34	80	3,15	32	1,26	120	4,72	12,6	0,50	70	2,76	9	0,35	4	F07	31	1,22	2,5	5,51
65	2 1/2"	45	1,77	175	6,89	89	3,50	32	1,26	136	5,35	12,6	0,50	70	2,76	9	0,35	4	F07	45	1,77	3,2	7,05
80	3"	45	1,77	181	7,13	95	3,74	32	1,26	160	6,30	12,6	0,50	70	2,76	9	0,35	4	F07	64	2,52	3,6	7,94
100	4"	52	2,05	200	7,87	114	4,49	32	1,26	185	7,28	15,77	0,62	70	2,76	9	0,35	4	F07	91	3,58	4,6	10,14
125	5"	55	2,17	213	8,39	127	5,00	32	1,26	215	8,46	18,92	0,74	70	2,76	9	0,35	4	F07	110	4,33	7	15,43
150	6"	56	2,20	226	8,90	139	5,47	32	1,26	238	9,37	18,92	0,74	70	2,76	9	0,35	4	F07	146	5,75	7,8	17,20
200	8"	61	2,40	260	10,24	175	6,89	45	1,77	295	11,61	22,1	0,87	102	4,02	11	0,43	4	F10	193	7,60	13,2	29,10
250	10"	66	2,60	292	11,50	203	7,99	45	1,77	357	14,06	28,45	1,12	102	4,02	11	0,43	4	F10	241	9,49	19,2	42,33
300	12"	77	3,03	337	13,27	242	9,53	45	1,77	407	16,02	31,6	1,24	102	4,02	11	0,43	4	F10	292	11,50	32,5	71,65
350	14"	77	3,03	368	14,49	267	10,51	45	1,77	467	18,39	31,6	1,24	125	4,92	13	0,51	4	F12	329	12,95	41,3	91,05
400	16"	87	3,43	400	15,75	309	12,17	72	2,83	525	20,67	33,15	1,31	125	4,92	13	0,51	4	F12	376	14,80	61	134,48
450	18"	106	4,17	422	16,61	328	12,91	72	2,83	585	23,03	38	1,50	140	5,51	18	0,71	4	F14	425	16,73	79	174,16
500	20"	132	5,20	480	18,90	361	14,21	82	3,23	650	25,59	41,15	1,62	140	5,51	18	0,71	4	F14	475	18,70	128	282,19
550	22"	154	6,06	510	20,08	397	15,63	82	3,23	715	28,15	50,65	1,99	140	5,51	18	0,71	4	F14	507	19,96	140	308,65
600	24"	154	6,06	562	22,13	459	18,07	82	3,23	816	32,13	50,65	1,99	165	6,50	22	0,87	4	F16	573	22,56	188	414,47
650	26"	165	6,50	580	22,83	470	18,50	82	3,23	825	32,48	63,35	2,49	165	6,50	22	0,87	4	F16	606	23,86	215	473,99
700	28"	165	6,50	624	24,57	520	20,47	82	3,23	895	35,24	63,35	2,49	165	6,50	22	0,87	4	F16	674	26,54	252	555,56
750	30"	165	6,50	660	25,98	564	22,20	90	3,54	894	35,20	63,35	2,49	254	10,00	18	0,71	8	F25	727	28,62	290	639,34
800	32"	188	7,40	672	26,46	591	23,27	82	3,23	1015	39,96	63,35	2,49	254	10,00	18	0,71	8	F25	771	30,35	368	811,30
900	36"	203	7,99	720	28,35	656	25,83	118	4,65	1115	43,90	75	2,95	254	10,00	18	0,71	8	F25	839	33,03	465	1025,15
950	38"	216	8,50	760	29,92	690	27,17	118	4,65	1195	47,05	75	2,95	254	10,00	18	0,71	8	F25	889	35,00	550	1212,54
1000	40"	216	8,50	800	31,50	721	28,39	142	5,59	1230	48,43	85	3,35	254	10,00	18	0,71	8	F25	939	36,97	606	1336,00
1100	44"	255	10,04	826	32,52	771	30,35	142	5,59	1404	55,28	94,7	3,73	298	11,73	22	0,87	8	F30	1036	40,79	895	1774,72
1200	48"	276	10,87	941	37,05	874	34,41	150	5,91	1511	59,49	107,7	4,24	295	11,61	22	0,87	8	F30	1137	44,76	900	1984,16
1400	56"	279	10,98	1000	39,37	940	37,01	175	6,89	1685	66,34	139,9	5,51	356	14,02	32	1,26	8	F35	1351	53,19	1158	2552,95
1600	64"	318	12,52	1155	45,47	1085	42,72	195	7,68	1930	75,98	160	6,30	356	14,02	32	1,26	8	F35	1548	60,94	1685	3714,78
1800	72"	356	14,02	1200	47,24	1170	46,06	195	7,68	2170	85,43	174,5	6,87	406	15,98	39	1,54	8	F40	1703	67,05	2645	5831,22
2000	80"	406	15,98	1363	53,66	1360	53,54	245	9,65	2345	92,32	199	7,83	406	15,98	39	1,54	8	F40	1938	76,30	4000	8818,48

Fitment Of Actuators:

The HMP™ _12A PN10 / 16 Concentric Wafer Type Butterfly Valves have an S05211 mounting flange suitable to directly fit any type of electric, pneumatic or hydraulic actuator.

Design Standards:

The HMP™ _12A PN10 / 16 Concentric Wafer Type Butterfly Valves are designed in accordance with various international standards as set out below:

- ANSI B16.34
- API 609
- ISO 5208

Multi-standard alignment holes suitable for various standard of flanges, allowing the valve to be fit between the following flange standards:

- ANSI B16.1 Class 125
- ANSI B16.5 Class 150
- BS 10 / AS2129 Table D and E
- BS 4504 / D.I.N. T10 and T16
- EN1092 PN10 and PN16
- JIS B2239 5K and 10K
- SANS 1123 T1000 and T1600



HMP™_12B PN10 / 16 Concentric Wafer Type Butterfly Valves with coated discs

Overview:

The HMP™_12B PN10 / 16 Concentric Wafer Type Butterfly Valves with coated discs are widely used in low pressure applications below 1.6 MPa such as water treatment, water distribution, mining, food and beverage, pulp and paper, chemical, and power plants. With its EDPM cartridge type seat (rubber liner) and streamlined disc, not a lot of force is needed for the closing of the valve. The main benefits of using the HMP™_12B PN16 Wafer Type Butterfly Valve is that it is very cost effective, small, easy to install, dirt are scraped from seat during closing operation and no gaskets are required to seal flange connections.

DN50 / 2" to DN600 / 24":

Lever Operated



Gearbox Operated



DN700 / 28" to DN2000 / 80":





HMP™ _12B PN10 / 16 Concentric Wafer Type Butterfly Valves with coated discs

Features:

- Media: Potable water, service water, wastewater, seawater, HVAC, Air, Vapour, food, pharmaceutical, oils, acid and Alkalis.
- Temperature range: -37 °C to + 150 °C / 35 °F to + 302 °F (depending on pressure, medium and material).
- Diameter nominal: DN50 – DN2000 / 2" – 80"
- Operating pressure: 1.6Mpa / 232 psi for DN50-DN600 / 2"-24", 1Mpa / 145 psi for DN350-DN2000 / 14"-80".
- Operation: Hand lever, gearbox, pneumatic actuator, electric actuator or hydraulic actuator.
- Mounting flange design: ISO5211
- Safety feature: Stem anti-blowout design.
- Connection: Wafer, lug design enables the valve to be installed between various flange standards and no gaskets are required to seal flange connections.

Materials Of Construction:

No	Part name	Specification	Specification - Optional					
			Ductile iron	Aluminium	Carbon steel			
1	Body	Cast iron	Ductile iron	Aluminium	Carbon steel			
2	Disc	Ductile iron - Plated	Ductile iron - Nylon	Ductile iron - PTFE	Carbon steel - Plated	Carbon steel - Nylon	Carbon steel - PTFE	Aluminium bronze
3	Shaft	SS 410	SS 304	SS 316	Monel			
4	Bush	Lubricated bronze	PTFE	Fibreglass backed PTFE				
5	Key	Key steel						
6	O-Ring	Nitrile (Buna)						
9	Lever	Cast Iron						
10	Gearbox housing	Cast Iron						
12	Handwheel	Cast Iron						
13	Seat	EDPM	Bona-N	PTFE	Neoprene	NBR	Hypalon	VITON
Seat temperature rating (°C)		-25 °C to 95 °C	-37 °C to 121 °C	-10 °C to 150 °C	-7 °C to 93 °C	-12 °C to 82 °C	-18 °C to 135 °C	-23 °C to 150 °C
Seat temperature rating (°F)		-13 F to 203 F	-35 F to 250 F	14 F to 302 F	19 F to 199 F	10 F to 180 F	0 F to 275 F	9 F to 302 F

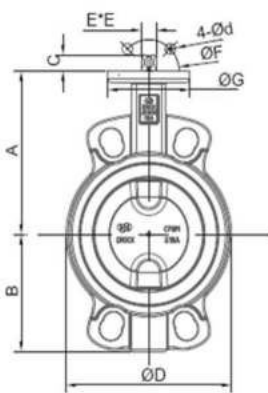

DN50-DN300

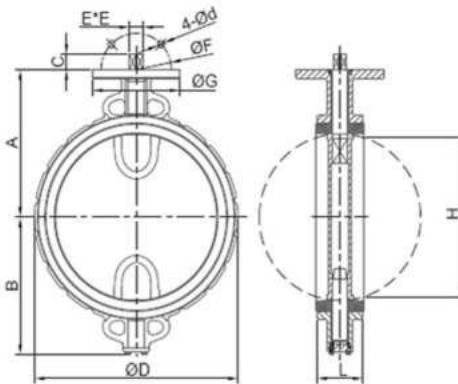

DN350-DN600

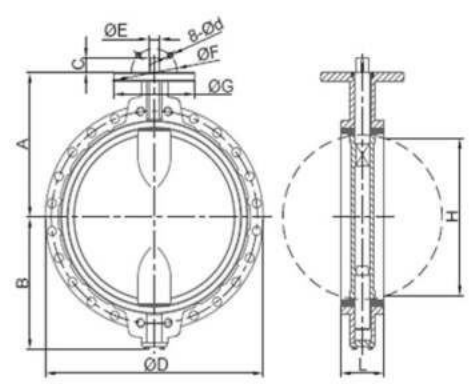

DN700-DN2000

Maximum Torque Requirement:

Valve Size		PN10	145 psi	PN16	232 psi	Valve Size		PN10	145 psi	PN16	232 psi
(DN)	(inch)	(N.m)	(ft.lbf)	(N.m)	(ft.lbf)	(DN)	(inch)	(N.m)	(ft.lbf)	(N.m)	(ft.lbf)
50	2"	9,5	7,0	12,7	9,4	250	10"	164	121,0	262	193,2
65	2 1/2"	12	8,9	15	11,1	300	12"	203	149,7	264	194,7
80	3"	16	11,8	21	15,5	350	14"	232	171,1	562	414,5
100	4"	23	17,0	30	22,1	400	16"	622	458,8	870	641,7
125	5"	41	30,2	53	39,1	450	18"	829	611,4	1161	856,3
150	6"	53	39,1	59	43,5	500	20"	1036	764,1	1451	1070,2
200	8"	68	50,2	100	73,8	600	24"	1314	969,2	1840	1357,1



HMP™ _12B PN10 / 16 Concentric Wafer Type Butterfly Valves with coated discs

Dimensions:

Valve Size		Face to face (L)		Centre to top flange (A)		Centre to bottom (B)		Top flange to top of shaft (C)		Diameter of body (D)		Diameter of shaft (E)		PCD (Ø) of mounting flange (F)		Mounting flange hole diameter (d), number of holes & ISO 5211 flange type (flg type)				Diameter of disk (G or H)		Mass	
(DN)	(inch)	(mm)	(inch)	(mm)	(inch)	(mm)	(inch)	(mm)	(inch)	(mm)	(inch)	(mm)	(inch)	(mm)	(inch)	(mm)	(inch)	hole no	flg type	(mm)	(inch)	(kg)	(lbs)
50	2"	42	1,65	161	6,34	80	3,15	32	1,26	120	4,72	12,6	0,50	70	2,76	9	0,35	4	F07	31	1,22	2,5	5,51
65	2 1/2"	45	1,77	175	6,89	89	3,50	32	1,26	136	5,35	12,6	0,50	70	2,76	9	0,35	4	F07	45	1,77	3,2	7,05
80	3"	45	1,77	181	7,13	95	3,74	32	1,26	160	6,30	12,6	0,50	70	2,76	9	0,35	4	F07	64	2,52	3,6	7,94
100	4"	52	2,05	200	7,87	114	4,49	32	1,26	185	7,28	15,77	0,62	70	2,76	9	0,35	4	F07	91	3,58	4,6	10,14
125	5"	55	2,17	213	8,39	127	5,00	32	1,26	215	8,46	18,92	0,74	70	2,76	9	0,35	4	F07	110	4,33	7	15,43
150	6"	56	2,20	226	8,90	139	5,47	32	1,26	238	9,37	18,92	0,74	70	2,76	9	0,35	4	F07	146	5,75	7,8	17,20
200	8"	61	2,40	260	10,24	175	6,89	45	1,77	295	11,61	22,1	0,87	102	4,02	11	0,43	4	F10	193	7,60	13,2	29,10
250	10"	66	2,60	292	11,50	203	7,99	45	1,77	357	14,06	28,45	1,12	102	4,02	11	0,43	4	F10	241	9,49	19,2	42,33
300	12"	77	3,03	337	13,27	242	9,53	45	1,77	407	16,02	31,6	1,24	102	4,02	11	0,43	4	F10	292	11,50	32,5	71,65
350	14"	77	3,03	368	14,49	267	10,51	45	1,77	467	18,39	31,6	1,24	125	4,92	13	0,51	4	F12	329	12,95	41,3	91,05
400	16"	87	3,43	400	15,75	309	12,17	72	2,83	525	20,67	33,15	1,31	125	4,92	13	0,51	4	F12	376	14,80	61	134,48
450	18"	106	4,17	422	16,61	328	12,91	72	2,83	585	23,03	38	1,50	140	5,51	18	0,71	4	F14	425	16,73	79	174,16
500	20"	132	5,20	480	18,90	361	14,21	82	3,23	650	25,59	41,15	1,62	140	5,51	18	0,71	4	F14	475	18,70	128	282,19
550	22"	154	6,06	510	20,08	397	15,63	82	3,23	715	28,15	50,65	1,99	140	5,51	18	0,71	4	F14	507	19,96	140	308,65
600	24"	154	6,06	562	22,13	459	18,07	82	3,23	816	32,13	50,65	1,99	165	6,50	22	0,87	4	F16	573	22,56	188	414,47
650	26"	165	6,50	580	22,83	470	18,50	82	3,23	825	32,48	63,35	2,49	165	6,50	22	0,87	4	F16	606	23,86	215	473,99
700	28"	165	6,50	624	24,57	520	20,47	82	3,23	895	35,24	63,35	2,49	165	6,50	22	0,87	4	F16	674	26,54	252	555,56
750	30"	165	6,50	660	25,98	564	22,20	90	3,54	894	35,20	63,35	2,49	254	10,00	18	0,71	8	F25	727	28,62	290	639,34
800	32"	188	7,40	672	26,46	591	23,27	82	3,23	1015	39,96	63,35	2,49	254	10,00	18	0,71	8	F25	771	30,35	368	811,30
900	36"	203	7,99	720	28,35	656	25,83	118	4,65	1115	43,90	75	2,95	254	10,00	18	0,71	8	F25	839	33,03	465	1025,15
950	38"	216	8,50	760	29,92	690	27,17	118	4,65	1195	47,05	75	2,95	254	10,00	18	0,71	8	F25	889	35,00	550	1212,54
1000	40"	216	8,50	800	31,50	721	28,39	142	5,59	1230	48,43	85	3,35	254	10,00	18	0,71	8	F25	939	36,97	606	1336,00
1100	44"	255	10,04	826	32,52	771	30,35	142	5,59	1404	55,28	94,7	3,73	298	11,73	22	0,87	8	F30	1036	40,79	805	1774,72
1200	48"	276	10,87	941	37,05	874	34,41	150	5,91	1511	59,49	107,7	4,24	295	11,61	22	0,87	8	F30	1137	44,76	900	1984,16
1400	56"	279	10,98	1000	39,37	940	37,01	175	6,89	1685	66,34	139,9	5,51	356	14,02	32	1,26	8	F35	1351	53,19	1158	2552,95
1600	64"	318	12,52	1155	45,47	1085	42,72	195	7,68	1930	75,98	160	6,30	356	14,02	32	1,26	8	F35	1548	60,94	1685	3714,78
1800	72"	356	14,02	1200	47,24	1170	46,06	195	7,68	2170	85,43	174,5	6,87	406	15,98	39	1,54	8	F40	1703	67,05	2645	5831,22
2000	80"	406	15,98	1363	53,66	1360	53,54	245	9,65	2345	92,32	199	7,83	406	15,98	39	1,54	8	F40	1938	76,30	4000	8818,48

Fitment Of Actuators:

The HMP™ _12B PN10 / 16 Concentric Wafer Type Butterfly Valves have an SO5211 mounting flange suitable to directly fit any type of electric, pneumatic or hydraulic actuator.

Design Standards:

The HMP™ _12B PN10 / 16 Concentric Wafer Type Butterfly Valves are designed in accordance with various international standards as set out below:

- ANSI B16.34
- API 609
- ISO 5208

Multi-standard alignment holes suitable for various standard of flanges allowing the valve to be fit between the following flange standards:

- ANSI B16.1 Class 125
- ANSI B16.5 Class 150
- BS 10 / AS2129 Table D and E
- BS 4504 / D.I.N. T10 and T16
- EN1092 PN10 and PN16
- JIS B2239 5K and 10K
- SANS 1123 T1000 and T1600



HMP™_TE Taper Pipe Coupling

Overview:

The HMP™_TE Taper pipe coupling is a high pressure pipe coupling, designed as an easy method of joining pipes. Also commonly termed quick couplings for steel pipes, the HMP™_TE couplings are used in high pressure piping systems. It speeds up installation time drastically when compared to flanges. The HMP™_TE was re-engineered by the Hydromine Projects International to be interchangeable with the original Anglo American / TE taper pipe coupling.

Using the HMP™_TE coupling will result in lower total capital expenditure due to the fact that it has a lower procurement cost, more pipes can be loaded per truck or rail carriage load, it takes less space when stored and most importantly, there will be a saving on labour as installation is quicker and easier than flanges. It can be installed in vertical mine shafts, inclines or horizontally. The HMP™_TE coupling can be used in pipe lines carrying liquids or abrasive material and is perfect for mining backfill pipes. The HMP™_U-Coupling is newer technology and more cost effective than the HMP™_TE coupling.



The HMP™_TE pipe coupling can be installed in a system where pipes hang on chains, parrot swings or are U-Bolted down onto pipe supports. Pipes should be anchored before and after every change of direction. The full range of HMP™ valves, expansion joints and energy dissipator can be manufactured with HMP™_TE coupling end connections.

Bolt Torque Settings:

Pipe sizes	Bolt Torque Figures						Equivalent ANSI Flanges			
	Pressure rating		Bolts sizes		Bolt torque		Number of bolts	Bolts sizes		Number of bolts
	(Mpa)	(Psi)	(metric)	(imperial)	(Nm)	ft lb		(metric)	(imperial)	
DN50 / 2"	25	3626	M16	5/8"	210	154.89	2	M24	1"	8
DN80 / 3"	25	3626	M16	5/8"	210	154.89	2	M30	1 1/4"	8
DN100 / 4"	25	3626	M16	5/8"	210	154.89	2	M35	1 1/4"	8
DN150 / 6"	25	3626	M20	3/4"	425	313.46	2	M36	1 1/2"	12
DN200 / 8"	25	3626	M24	1"	730	538.42	2	M42	1 3/4"	12

Materials Of Construction:

Part Name	Material Specification
Clamps	Casting - BS3100 Grade A2
Hubs # 1	Carbon steel
Hubs # 2	ASTM A105
Bolts	Grade 8.8, Hot dipped galvanized
Seals # 1	O-Ring - nitrile (Buna)
Seals # 2	O-Ring - polyurethane

Design & Manufacturing Standards:

The HMP™_TE Hydraulic coupling are designed in accordance with various international standards as set out below:

ASME Boilers and pressure vessels design code

ANSI B16.3

ANSI B16.34

ANSI N278.1

ANSI B16.37

Available sizes: DN50 / 2" to DN200 / 8"

Pressure rating: up to 25MPa / 3 626 Psi



HMP™_TE Taper Pipe Coupling

Parts:



Plain ended butt welded hub, welded to pipe



Grooved butt welded hub, welded to pipe



Locating ring & O-Ring (seal)



Hubs, O-Ring and locating ring assembled



1 x half clamp assembled with hubs, O-Ring and locating ring

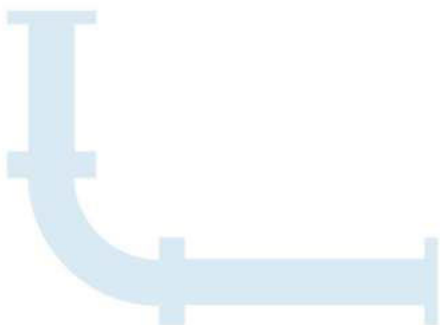



HMP™ U-Coupling (Taper Pipe Coupling)

Overview:

The HMP™ U-Coupling is a high pressure pipe coupling designed as an easy method of joining pipes. Sometimes referred to as a quick couplings for steel pipes, the U-Couplings are used in medium to high pressure piping systems. It speeds up installation time drastically when compared to flanges. Using the HMP™ U-Coupling will result in lower capital expenditure, due to the fact that it has a lower procurement cost, more pipes can be loaded per truck or rail carriage load, it takes less space when stored and most importantly, there will be a saving on labour, as installation is quicker and easier than flanges. It can be installed in vertical mine shafts, inclines or horizontally. The HMP™ U-Coupling can be used in pipe lines carrying liquids or abrasive material and is perfect for mining backfill pipes.

The HMP™ U-Coupling can be installed in a system where pipes hang on chains, parrot swings or are U-Bolted down onto pipe supports. Pipes should be anchored before and after every change of direction. The full range of HMP™ valves, expansion joints and energy dissipator can be manufactured with U-Coupling end connections.



There are two types of HMP™ U-Coupling the first type is the "A" type which has two identical hubs. The "A" type can be used with a UHMWPE or PTFE compression seal. The "A" type does not require the use of an alignment ring as the seal aligns the pipe. Furthermore, the "A" is sexless which makes installation easier, especially on valves or pipe fitting. The second type, type "B" effects a seal using a nitrile or polyurethane O-ring. The "B" types hubs are slightly different, one side of the hub is grooved to accommodate the seal and the other hub has a flat surface which compresses the seal into the groove. It requires an alignment ring to ensure correct hub alignment. Care needs to be taken when installation is done as long length of pipes cannot be turned around in narrow spaces and underground tunnels.

Bolt Torque Settings:

Pipe sizes	Bolt Torque Figures							Equivalent ANSI Flanges		
	Pressure rating		Bolts sizes		Bolt torque		Number of bolts	Bolts sizes		Number of bolts
	(Mpa)	(Psi)	(metric)	(imperial)	(Nm)	(ft lb)		(metric)	(imperial)	
DN50 / 2"	25	3626	M10	7/16"	50	36.88	2	M24	1"	8
DN80 / 3"	25	3626	M12	1/2"	85	62.69	2	M30	1 1/4"	8
DN100 / 4"	25	3626	M16	5/8"	210	154.89	2	M33	1 1/4"	8
DN150 / 6"	25	3626	M16	5/8"	210	154.89	4	M36	1 1/2"	12
DN150 / 6"	16	2320	M20	3/4"	425	313.46	2	M30	1 1/4"	12
DN200 / 8"	25	3626	M20	3/4"	425	313.46	4	M42	1 3/4"	12
DN200 / 8"	16	2320	M24	1"	730	538.42	2	M36	1 1/2"	12
DN250 / 10"	25	3626	M30	1 1/4"	1440	1062.09	4	M48	2"	12
DN250 / 10"	16	2320	M20	3/4"	425	313.46	4	M36	1 1/2"	16
DN250 / 10"	10	1450	M24	1"	730	538.42	2	M33	1 1/4"	16
DN300 / 12"	25	3626	M30	1 1/4"	1440	1062.09	4	M48	2"	16
DN300 / 12"	16	2320	M20	3/4"	425	313.46	4	M36	1 1/2"	20
DN300 / 12"	10	1450	M20	3/4"	425	313.46	4	M33	1 1/4"	20
DN350 / 14"	25	3626	M36	1 1/2"	1885	1390.30	4	M56	2 1/4"	16
DN350 / 14"	16	2320	M20	3/4"	425	313.46	4	M39	1 3/4"	20
DN350 / 14"	10	1450	M20	3/4"	425	313.46	4	M36	1 1/2"	20
DN400 / 16"	16	2320	M24	1"	730	538.42	4	M42	1 3/4"	20
DN400 / 16"	10	1450	M20	3/4"	425	313.46	4	M39	1 3/4"	20

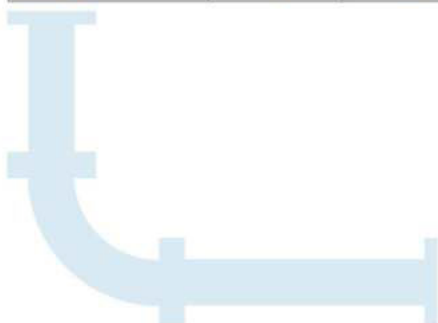



HMP™ U-Coupling (Taper Pipe Coupling)

Parts "A" Type:



Butt welded hubs



Compression seal



Butt welded hubs & compression seal



Clamp set



1 x half clamp with hubs assembled

Parts "B" Type:



Plain ended butt welded hub, welded to pipe



Grooved butt welded hub, welded to pipe



Locating ring & O-Ring (seal)



Hubs, O-Ring and locating ring assembled



1 x half clamp assembled with hubs, O-Ring and locating ring

Design & Manufacturing Standards:

The HMP™ Hydraulic coupling are designed in accordance with various international standards as set out below:

ASME Boilers and pressure vessels design code

ANSI B16.3

ANSI B16.34

ANSI N278.1

ANSI B16.37

Available sizes: DN50 / 2" to DN500 / 16"

Pressure rating: up to 25MPa / 3 626 Psi



Materials Of Construction:

Part Name	Material Specification
Clamps	Casting - BS3100 Grade A2
Hubs # 1	Hollow bar - ST-52
Hubs # 2	ASTM A105
Bolts	Grade 8.8, Hot dipped galvanized
Seals # 1	UHMWPE
Seals # 2	PTFE
Seals # 3	O-Ring - nitrile (Buna)
Seals # 4	O-Ring - polyurethane



HMP™ Range of Hydraulic Pipe Couplings

Overview:

The HMP™ Hydraulic coupling is designed as an easy method of joining plain ended pipes in a vertical shaft. The coupling allows for expansion and contraction. It eliminates the expensive welding process, saves space and drastically reduces installation time.

The HMP™ Hydraulic coupling can only be installed in a system where each pipe is supported. The top and bottom pipes in the shaft must be properly anchored. The coupling allows for expansion and contraction and no other expansion joints will be required. All pipe ends must be properly prepared for the installation and must be free of scratches, dents or any damage. If the pipe ends are well prepared, and the coupling is installed as per the installation procedure, the chances of leaks are drastically reduced.

Designed Gap:

There should be a gap between the pipes when they are installed in the shaft. This gap will allow for expansion, contraction of the pipe and the centre bolts / pins of the HMP™ Hydraulic coupling. In most cases the design gap will be 25mm / 0,98". The design gap must be calculated and specified by the engineer, who is in charge of the design of the entire piping system.

Should the design gap be greater than 25mm / 0,98", the face to face of the coupling will be greater than in the specified table below.

Materials Of Construction:

Part Name	Material Specification
Body - #1	Pipe - ASTM A106 Grade B
Body - #2	Hollow bar - ST-52
Body - #3	Casting - BS3100 Grade A2
Flanges - #1	ASTM A105
Flanges - #2	Carbon steel
Centre bolts / pins	316 S/Steel
Dowty washer	304 S/Steel / Nitrile
Seals	Polyurethane
Bolts	Hex Grade 8.8, Hot dipped galvanizing



Dimensions:

Pipe sizes	Inner bolt dimensions				Outer bolt dimensions			
	Face to Face		Outside diameter		Face to Face		Outside diameter	
	(mm)	(inch)	(mm)	(inch)	(mm)	(inch)	(mm)	(inch)
DN50 / 2"	180	7.09	145	5.71	180	7.09	180	7.09
DN80 / 3"	190	7.48	175	6.89	190	7.48	190	7.48
DN100 / 4"	200	7.87	200	7.87	200	7.87	230	9.06
DN150 / 6"	200	7.87	260	10.24	200	7.87	274	10.79
DN200 / 8"	220	8.66	305	12.01	220	8.66	355	13.98
DN250 / 10"	220	8.66	360	14.17	220	8.66	410	16.14
DN300 / 12"	250	9.84	420	16.54	250	9.84	465	18.31
DN350 / 14"	250	9.84	450	17.72	250	9.84	480	18.90
DN400 / 16"	250	9.84	500	19.69	250	9.84	575	22.64
DN450 / 18"	250	9.84	565	22.24	250	9.84	645	25.39
DN500 / 20"	300	11.81	630	24.80	300	11.81	740	29.13



HMP™ Range of Hydraulic Pipe Couplings

Bolt Dimensions And Torque Settings:

Pipe sizes Unit	Bolts sizes		Bolt torque		Centre bolt sizes	
	(metric)	(imperial)	(Nm)	ft lb		
DN50 / 2"	M12	1/2"	85	62.69	3 x M12	3 x 1/2"
DN80 / 3"	M12	1/2"	85	62.69	3 x M12	3 x 1/2"
DN100 / 4"	M16	5/8"	210	154.89	3 x M12	3 x 1/2"
DN150 / 6"	M16	5/8"	210	154.89	3 x M16	3 x 5/8"
DN200 / 8"	M16	5/8"	210	154.89	3 x M16	3 x 5/8"
DN250 / 10"	M16	5/8"	210	154.89	3 x M16	3 x 5/8"
DN300 / 12"	M20	3/4"	425	313.46	3 x M16	3 x 5/8"
DN350 / 14"	M20	3/4"	425	313.46	4 x M16	4 x 5/8"
DN400 / 16"	M20	3/4"	425	313.46	4 x M20	4 x 3/4"
DN450 / 18"	M24	1"	730	538.42	4 x M20	4 x 3/4"
DN500 / 20"	M24	1"	730	538.42	6 x M20	6 x 3/4"

Design & Manufacturing Standards:

The HMP™ Hydraulic coupling are designed in accordance with various international standards as set out below:

ASME Boilers and pressure vessels design code

ANSI B16.3

ANSI B16.34

ANSI N278.1

ANSI B16.37

Available sizes: DN50 / 2" to DN500 / 16"

Pressure rating: up to 25MPa / 3 626 Psi

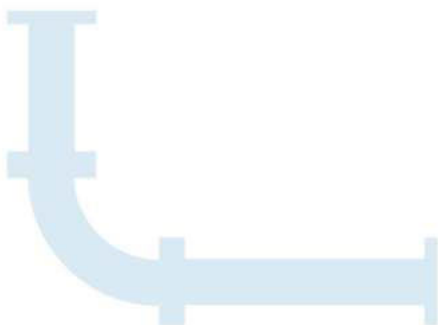



LFC™ _1B Electrically Actuated Isolation Valve

Overview:

The LFC™ _1B Electrically actuated Isolating valves were designed to be energy efficient with a low flow co-efficient (Cv), simple and easy to operate.

Due to the hydraulically balanced design and low torque requirements the valve requires a relatively small electrical actuator with no external gearbox. This feature saves capital and long-term maintenance costs. Any make of electrical actuator can be fitted on the LFC™ _1B electrically actuated isolation valve. The LFC™ _1B electrically actuated isolation valves are generally used in pump discharge control, PLC regulated control or any other automated applications.

Low Operating Torque:

The LFC™ _1B Electrically actuated isolating valve is hydrostatically balanced to enable easy opening and closing at any pressure and differential conditions. It does not require the use of a gearbox or a by-pass valve to balance pressure between the inlet and outlet. The differential pressures do not affect the operating torque which results in a relatively flat torque curve allowing for the fitment of smaller actuators.

Cv Value & Energy Efficiency Reduced Operating Costs):

One of the primary costs after the initial capital outlay is running costs, especially in a pump station. A valve's Cv refers to the number of US gallons of water per minute at 60F that will flow through a valve with a pressure drop of one psi and is indirectly proportional to the amount of energy consumed to drive water through the valve. Cv should therefore be factored into the running cost of the system as it directly affects pumping cost and energy expense incurred to achieve the pumping volume requirements. Valves with better Cv values offer quantifiable energy savings over time.

Operating Conditions:

These valves are designed to operate in systems with relatively clean media like water or other liquids with a low percentage of suspended solids and chlorides. The valve's operating pH range is 2 - 14 pH.

Simplicity:

The LFC™ _1B valve is designed to minimize wearing parts and in effect only has one moving part called the plug. The plug is a piston that is engineered to be balanced. The balanced plug uses the inline fluid pressure to remove the influence of differential pressure on operating torque. As such, the valve operating torque is the torque required to overcome the sum of the friction forces generated between the valve seals and the sleeve plus the weight of the plug (depending on the installation configuration). This torque requirement is not affected by inline pressure variants and as such makes the balanced valves extremely good for actuation applications as well as for isolation valves where manual operation is required. Removal of gearboxes reduces maintenance requirements and improves troubleshooting times.

Low Maintenance Requirement:

All the moving parts of the LFC™ _1B Electrically actuated manual isolation valves are manufactured from stainless steel which increases reliability and durability. The LFC™ _1B Electrically actuated manual isolation valve requires minimal maintenance, the majority of which, can be conducted with the valve remaining in situ.

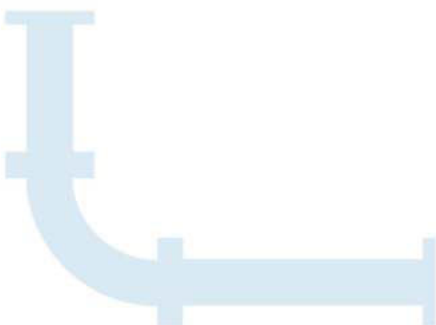



LFC™ _1B Electrically Actuated Isolation Valve

Materials Of Construction & Dimensions:

Part Name	Material Specification	Unit	Face To Face Dimensions					
			#600		#900		#1500	
			(mm)	(Inch)	(mm)	(Inch)	(mm)	(Inch)
Body - DN50 to DN100	Casting - 431 S/Steel							
Body - DN150 to DN400	Casting - BS3100 Gr. A2							
Body seat - #1	431 S/Steel	DN50 / 2"	292	11.50	368	14.49	368	14.49
Body seat - #2	F6	DN80 / 3"	356	14.02	381	15.00	470	18.5
Body seat - #3	F12	DN100 / 4"	432	17.01	457	17.99	546	21.50
Flanges	ASTM A105	DN150 / 6"	559	22.01	610	24.02	705	27.76
Plug	431 S/Steel	DN200 / 8"	660	25.98	737	29.02	832	32.76
Plug Seat - #1	UHMWPE	DN250 / 10"	787	30.98	838	32.99	991	39.02
Plug Seat holder - #1	431 or 304 S/Steel	DN300 / 12"	838	32.99	965	37.99	1130	44.49
Plug Seat - #2	431 S/Steel							
Seal clamp	431 or 304 S/Steel							
Sleeve - DN150 to DN400	431 or 304 S/Steel							
Top cover	Carbon steel							
Spindle	431 S/Steel							
Bush holder	Carbon steel							
Tripod rods	Carbon steel							
Plug Seals	Polyurethane							
Shaft Seal	Polyurethane							
Wiper Seal	Polyurethane							
O-Rings	Nitrile (Buna)							

Flow Rates:

Flow (ℓ/sec)	5	10	25	35	50	100	150	200	250	300
Pressure Drop (kPa)	DN50	17	81							
	DN80	5	35	90						
	DN100		1.5	30	45	98				
	DN150			2.5	6.5	15	57			
	DN200					2.5	14	42	76	
	DN250						7	17	27	46
	DN300									65
Flow US gallon/ min	79.25	158.50	396.26	554.76	792.52	1585.03	2377.55	3170.06	3962.58	4755.09
Pressure Drop (psi)	2"	2.47	11.75							
	3"	0.73	5.08	13.05						
	4"		0.22	4.35	6.53	14.21				
	6"			0.36	0.94	2.18	8.27			
	8"					0.36	2.03	6.09	11.02	
	10"						1.02	2.47	3.92	6.67
	12"									9.43

Design & Manufacturing Standards:

The The LFC™ _1B electrically actuated valve has been designed in accordance with various international standards as set out below:

ASME Boilers and pressure vessels design code

ANSI B16.10 ANSI B16.3

ANSI B16.34 ANSI B16.37

ANSI B16.5 ANSI N278.1

Available sizes: DN50 / 2" to DN400 / 16"

Pressure rating: up to 25MPa / 3 626 psi

Face to face dimensions: ANSI B16.10 or other, minimum #600

Available end connections: ANSI B16.5, BS4504, BS10, AS/NZS 4331.1 (ISO 7005-1) DIN, all makes of grooved or ring joint couplings, HMP™ Coupling, HMP™ -TE tapered couplings and other as per clients requirement.





LFC™ _1B Excess Flow Shutdown Valves

Overview:

The LFC™ _1B Excess flow shutdown valve is designed to shut down the flow of water in a piping system when an incident such as a pipe burst, or pipe break occurs. In most water piping systems, an instantaneous shutdown operation can cause a water hammer that could result in serious damage to the piping system. In such a case, water will also continuously run out of the system until it is manually isolated for the problem to be attended to, and as a result a very high volume of water can get wasted. It is often not considered that the high volume of water wastage can substantially increase the cost of operating as well.

In such a case, the flow of water is required to be managed in a controlled manner by the use of a control valve that can gradually close off and reduce the flow of the water. Should there be a valve in the system that can automatically sense the pipe burst or break and shut down automatically such as the LFC™ _1B Excess flow shutdown valve, the risks will be mitigated and the wastage of water can be controlled, which will eventually result in substantial cost savings.

The LFC™ _1B Excess flow shutdown valve works on a very similar principal as a fuse in an electrical circuit, however, a fuse is designed to stop the flow of current instantaneously when the draw exceeds the maximum fuse rating, whereas the LFC™ _1B Excess flow shutdown valve is designed to shut down in a gradual and controlled manner.

The valve is designed to execute this type of operation automatically, and it will start to close off when the desired set-flow (pre-set has been reached, thereby aiding in preventing a water hammer that could cause damage to the piping system from occurring.

The LFC™ _1B Excess flow shutdown valve is designed to present a robust, simple and cost-effective solution to fluid handling issues in any industrial sector, off up to 25 MPa / 3 626 psi.

Design Features:

At the core, the LFC™ _1B range of Excess flow shutdown valves are designed with simplicity in mind. It has one only moving part called the plug assembly, which in effect minimizes the wear and tear of the valve, thereby increasing the valve's overall life span.

The plug assembly is a piston that is engineered to be unbalanced, and uses the valve's inline fluid pressure to control the differential pressures that influences it's operating torque. As such, the valve's operating torque induced by the plug assembly is all that is required to overcome the sum of all counter frictional forces generated by the valve's seals, sleeve, cylinder, and the weight of the plug assembly (depending on the installation configuration).

Under normal conditions, the downstream hydraulic pressure below the plug assembly keeps the valve in the open position via a primary hose arrangement. A secondary hose arrangement is used to feed a hydraulic pressure to the top of the plug assembly; however, the valve will remain open due to the reduced counteracting surface area on top of the plug assembly. The downstream pressure that keeps the valve open gets reduced with the help of the V-port assembly, and only when there is an actual instance of excess flow that takes place, the secondary hose arrangement that feeds the hydraulic pressure to the top of the plug assembly will start to exert a force that moves the plug assembly into the closed position.

As a safety feature, the LFC™ _1B range of Excess flow shutdown valves are design to remain closed when it shuts down and cannot open by itself. When the hydraulic force from the downstream side of the valve that acts below the plug assembly starts to become greater than the hydraulic force from the upstream side of the valve that keeps it closed, only then will the plug assembly start moving to the open position once again.

Alternatively, a 3-way L-Port ball valve can be installed to manually override the excess flow shutdown valve. A qualified operator will be required to manually execute this operation, once the necessary maintenance has been done. When the valve is fully closed, it will remain closed and will not open by itself. The upstream pressure which causes the valve to remain closed can be released by simply opening the 3-way valve (changing the lever position) to vent the fluid that is contained in the valves closing chamber. By closing off the upstream pressure with the 3-way valve and venting the valve's closing chamber, the valve will start to gradually reopen again in a controlled manner. The opening speed of the valve can be controlled with an external variable orifice (needle valve).

A bypass system designed to fill the piping system can also be installed to prevent water hammer and pipe shocking, especially in large bore piping systems. If a bypass system is used, the excess flow shutdown valve will only start opening when the downstream piping is close to reaching the fully charged line pressure. It is recommended to install an air release/vacuum break valve in the piping system after the excess flow shutdown valve, to release the air from the system while it is filling.





LFC™ _1B Excess Flow Shutdown Valves

Dealing With Cavitation:

In most water reticulation and piping applications, most valves will always experience cavitation at the initial opening and final closing stages. The LFC™ _1B Excess flow shutdown valve has been designed to reduce the effects of cavitation on the seating areas by the use of a specially designed V-port device which work in conjunction with the Plug assembly. The Images below shows various open positions of the LFC™ _1B Excess flow shutdown valve's V-port arrangement. This is shown at incremental percentages for illustration purposes.



Figure 1: V-Port Open Positions At Incremental Percentages

Figure 1: 100% Open Position.

This illustration shows the Plug assembly in a 100% open position. Now, it can clearly be seen that the V-port is fully open, and the flow path is only slightly restricted. At this point, the flow is at its full demanded flow rate, and the V-port has little to no function. During a pipe burst or pipe break, the slightly restricted flow path will generate a pressure drop that is sufficient enough for the excess flow shutdown valve to sense a differential pressure and start shutting down. The flow direction is from inside the body seat and V-Port to the outside diameter of the V-Port.

Figure 2: 75% Open Position.

This illustration shows the Plug assembly in a 75% open position. It can clearly be seen that the V-port is almost fully open, and the flow path is still slightly reduced. After a pipe burst or break has occurred, the LFC™ _1B Excess flow shutdown valve will start to close off in a controlled manner and reduce the flow in a linear pattern as it closes.

Figure 3: 50% Open Position.

This illustration shows the Plug assembly in a 50% open position. It can clearly be seen that the V-port is nearly half open, while the flow path is still reduced.

Figure 4: 30% Open Position.

This illustration shows the Plug assembly in a 30% open position. It can clearly be seen that the V-port creates a smaller orifice area, and the flow path is getting reduced. From this point, cavitation needs to be dealt with to increase the life expectancy of the valve. The V-port trim ensures that the seating elements are further apart from each other during a low flow condition, which allows cavitation to take place on the non-critical components of the valve.

Figure 5: 15% Open Position.

This illustration shows the Plug assembly in a 15% open position. It can be observed that the opening is proportionally reduced as the V-port opening becomes smaller at this point, the top of the V-port is exposed to a reduced flow path. This reduces cavitation at the low flow conditions.

Figure 6: 5% Open Position.

This illustration shows the Plug assembly in a 5% open position. It can be seen that the opening at the top of the V-Port is just slightly exposed and is very small. This reduces cavitation at low flow conditions.

Figure 7: Closed Position.

This illustration shows the Plug assembly completely seated against the valve body, in a fully closed position. This indicates that the valve is fully closed.

Operating Method:

The LFC™ _1B range of Excess flow shutdown valves are hydrostatically operated and does not require any external equipment such as sensing devices, controllers, actuators, or electrical connections to operate. It can be installed in remote places where there is no access to electricity.

Operating Conditions:

The LFC™ _1B range of valves are designed to operate in systems with relatively clean mediums like water, or other liquids with a low percentage of suspended solids and chlorides. The valve's operating pH range is between 2 - 14 ph.



LFC™ _1B Excess Flow Shutdown Valves

Flow Rates:

Flow (ℓ/sec)		5	10	25	35	50	100	150	200	250	300
Pressure Drop (kPa)	DN50	17	81								
	DN80	5	35	90							
	DN100		1.5	30	45	98					
	DN150			2.5	6.5	15	57				
	DN200					2.5	14	42	76		
	DN250						7	17	27	46	65
DN300											
Flow US gallon / min		79.25	158.50	396.26	554.76	792.52	1585.03	2377.55	3170.06	3962.58	4755.09
Pressure Drop (psi)	2"	2.47	11.75								
	3"	0.73	5.08	13.05							
	4"		0.22	4.35	6.53	14.21					
	6"			0.36	0.94	2.18	8.27				
	8"					0.36	2.03	6.09	11.02		
	10"						1.02	2.47	3.92	6.67	9.43
	12"										

Dimensions:

Unit	Face to face Dimensions:							
	#300		#600		#900		#1500	
	(mm)	(inch)	(mm)	(inch)	(mm)	(inch)	(mm)	(inch)
DN50 / 2"	292	11.50	292	11.50	368	14.49	368	14.49
DN80 / 3"	356	14.02	356	14.02	381	15.00	470	18.50
DN100 / 4"	432	17.01	432	17.01	457	17.99	546	21.50
DN150 / 6"	559	22.01	559	22.01	610	24.02	705	27.76
DN200 / 8"	660	25.98	660	25.98	737	29.02	832	32.76
DN250 / 10"	787	30.98	787	30.98	838	32.99	991	39.02
DN300 / 12"	838	32.99	838	32.99	965	37.99	1130	44.49
DN350 / 14"	889	35.00	889	35.00	1029	40.51	1257	49.49
DN400 / 16"	991	39.02	991	39.02	1130	44.49	1384	54.49

Material Specifications:

Part Description	Material Specification
Body	431 S/Steel
Body seat	431 S/Steel
Plug	431 / 304 S/Steel
V-port or Seat holder	431 / 304 S/Steel
Shaft	431 / 304 S/Steel
Piston	431 / 304 S/Steel
Plug seat	Polyurethane / UHMWPE / 431 S/Steel
Sleeve	304 S/Steel
Cylinder	304 S/Steel
Cylinder holder	Carbon Steel
Cylinder top cover	Carbon Steel
Indication rod	431 / 304 S/Steel
Hoses	Single braided
Seals	Polyurethane
O-Rings	Bona N

Valve Sizing:

Please consult with a technical expert at Hydromine Projects International for clarification on correct valve sizing on your specific requirements.

Maintenance Requirements:

The LFC™ _1B range of valves require minimal maintenance, the majority of which can be conducted with the valve remaining in situ. All moving parts of LFC™ _1B Excess flow shutdown valve is manufactured from stainless steel which increases their reliability and durability.

Design & Manufacturing Standards:

The LFC™ _1B Excess flow shutdown valve is designed in accordance with various International Boiler and Pressure vessel standards, as set out below:
 ASME Boilers and pressure vessels design code
 ANSI B16.10 ANSI B16.3
 ANSI B16.34 ANSI B16.37
 ANSI B16.5 ANSI N278 .1

Available sizes: DN50 / 2" to DN400 / 16"
 Face to face dimensions to ANSI B16.10
 Pressure rating: up to 25MPa / 3 626 psi

Available end connections: ANSI B16.5, BS4504, BS10, AS/NZS 4331.1
 (ISO 7005-1) DIN, all makes of grooved or ring joint couplings, and various other types, as per client requirements.



LFC™ _1B Manual Isolation Valves

Overview:

The LFC™ _1B Manual isolation valve is manually operated via a handwheel and mechanical spindle arrangement. The spindle arrangement also functions as an indication mechanism, and based on the position of the spindle, it can be clearly seen if the valve is in an open or closed position.

The Isolating valve ranges were designed to be energy efficient with a low flow co-efficient (Cv), simple and easy to operate.

Low Operating Torque:

The LFC™ _1B manual isolation valve is hydrostatically balanced to enable easy opening and closing at any pressure and differential conditions. It does not require the use of a gearbox or a by-pass valve to balance pressure between the inlet and outlet. The differential pressures do not affect the operating torque which results in a relatively flat torque curve allowing for the fitment of smaller actuators.

Cv Value & Energy Efficiency (Reduced Operating Costs):

One of the primary costs after the initial capital outlay is running costs, especially in a pump station.

A valve's Cv refers to the number of US gallons of water per minute at 60F that will flow through a valve with a pressure drop of one psi and is indirectly proportional to the amount of energy consumed to drive water through the valve. Cv should therefore be factored into the running cost of the system as it directly affects pumping cost and energy expense incurred to achieve the pumping volume requirements. Valves with better Cv values offer quantifiable energy savings over time.

Operating Conditions:

These valves are designed to operate in systems with relatively clean media like water or other liquids with a low percentage of suspended solids and chlorides. The valve's operating pH range is 2 - 14 pH.

Simplicity:

The LFC™ _1B valve is designed to minimize wearing parts and in effect only has one moving part called the plug. The plug is a piston that is engineered to be balanced. The balanced plug uses the inline fluid pressure to remove the influence of differential pressure on operating torque. As such, the valve operating torque is the torque required to overcome the sum of the friction forces generated between the valve seals and the sleeve plus the weight of the plug (depending on the installation configuration). This torque requirement is not affected by inline pressure variants and as such makes the balanced valves extremely good for actuation applications as well as for isolation valves where manual operation is required. Removal of gearboxes reduces maintenance requirements and improves troubleshooting times.

Flow Rates:

Flow (l/sec)		5	10	25	35	50	100	150	200	250	300
Pressure Drop (kPa)	DN50	17	81								
	DN80	5	35	90							
	DN100		1.5	30	45	98					
	DN150			2.5	6.5	15	57				
	DN200					2.5	14	42	76		
	DN250						7	17	27	46	65
	DN300										
Flow US gallon / min		79.25	158.50	396.26	554.76	792.52	1585.03	2377.55	3170.06	3962.58	4755.09
Pressure Drop (psi)	2"	2.47	11.75								
	3"	0.73	5.08	13.05							
	4"		0.22	4.35	6.53	14.21					
	6"			0.36	0.94	2.18	8.27				
	8"					0.36	2.03	6.09	11.02		
	10"						1.02	2.47	3.92	6.67	9.43
	12"										

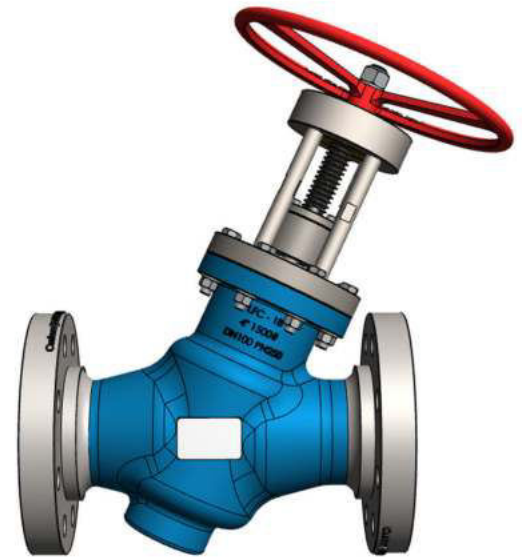



LFC™ _1B Manual Isolation Valves

Materials Of Construction & Dimensions:

Part Name	Material Specification	Unit	Face To Face Dimensions					
			#600		#900		#1500	
			(mm)	(Inch)	(mm)	(Inch)	(mm)	(Inch)
Body - DN50 to DN100	Casting - 431 S/ Steel							
Body - DN150 to DN400	Casting - BS3100 Gr. A2							
Body seat - #1	431 S/ Steel	DN50 / 2"	292	11.50	368	14.49	368	14.49
Body seat - #2	F6	DN80 / 3"	356	14.02	381	15.00	470	18.5
Body seat - #3	F12	DN100 / 4"	432	17.01	457	17.99	546	21.50
Flanges	ASTM A105	DN150 / 6"	559	22.01	610	24.02	705	27.76
Plug	431 S/ Steel	DN200 / 8"	660	25.98	737	29.02	832	32.76
Plug Seat - #1	UHMWPE	DN250 / 10"	787	30.98	838	32.99	991	39.02
Plug Seat holder - #1	431 or 304 S/Steel	DN300 / 12"	838	32.99	965	37.99	1130	44.49
Plug Seat - #2	431 S/Steel							
Shaft	431 S/Steel							
Seal clamp	431 or 304 S/Steel							
Sleeve - DN150 to DN400	431 or 304 S/Steel							
Top cover	Carbon steel							
Spindle	431 S/Steel							
Drive bush	LG 2							
Bush holder	Carbon steel							
Bearing housing	431 or 304 S/Steel							
Bearing housing cover	431 or 304 S/Steel							
Bearings	Trust bearings							
Tripod rods	Carbon steel							
Handwheel	Cast iron							
Plug Seals	Polyurethane							
Shaft Seal	Polyurethane							
Wiper Seal	Polyurethane							
O-Rings	Nitrile (Buna)							

Low Maintenance Requirement:

All the moving parts of the LFC™ _1B manual isolation valves are manufactured from stainless steel which increases reliability and durability. The LFC™ _1B requires minimal maintenance, the majority of which, can be conducted with the valve remaining in situ.

The Manual isolation valve has an external bearing housing. The bearings can be greased via the installed grease nipple using a manual or automatic grease pump, while the valve is in service. Should the bearings get worn or damaged, they can be changed with the valve in an open position only, while the valve is in service.

Design & Manufacture Standards:

The LFC™ _1B manual isolation valve has been designed in accordance with various international standards as set out below:

ASME Boilers and pressure vessels design code

ANSI B16.10 ANSI B16.3

ANSI B16.34 ANSI B16.37

ANSI B16.5 ANSI N278.1

Available sizes: DN50 / 2" to DN400 / 16"

Pressure rating: up to 25MPa / 3 626 psi

Face to face dimensions: ANSI B16.10 or other, minimum #600

Available end connections: ANSI B16.5, BS4504, BS10, AS/NZS 4331.1 (ISO 7005-1) DIN, all makes of grooved or ring joint couplings, HMP™ Coupling, HMP™ -TE tapered couplings and other as per client's requirement

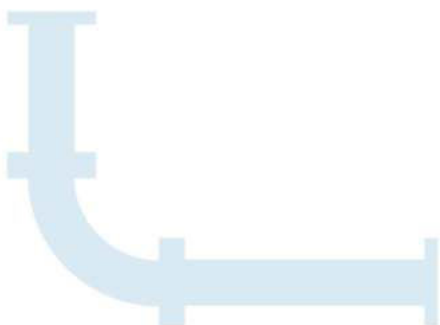



LFC™_1B Nitrogen Surge Relief Valve

Overview:

A surge relief valve is designed to open when a over pressure situation occurs and thereby prevent excessively high pressures from putting people and equipment at risk.

The LFC™_1B nitrogen charged surge relief valve has been developed to present a robust and simple solution to fluid handling issues in the mining sector.

Simplicity:

The LFC™_1B nitrogen charged surge relief valve is designed to minimize wearing parts and in effect only has one moving part called the plug assembly. The plug assembly is a piston that is engineered to be unbalanced. The unbalanced plug assembly together with the nitrogen pressure on top of the plug assembly, are designed to use inline fluid pressure to create specific conditions in the system without the use of an external controller or pilot.

A fixed opening force can be established by fixing the surface area ratio exposed to the upstream pressure and the nitrogen pressure combined. Upstream pressure (P_u) would act to open the valve. As the P_u increases, the opening force increases proportionally causing the nitrogen to compress and the valve to open. If P_u is reduced, the valve will close proportionally in an effort to maintain its hydraulic ratio and nitrogen force combined.

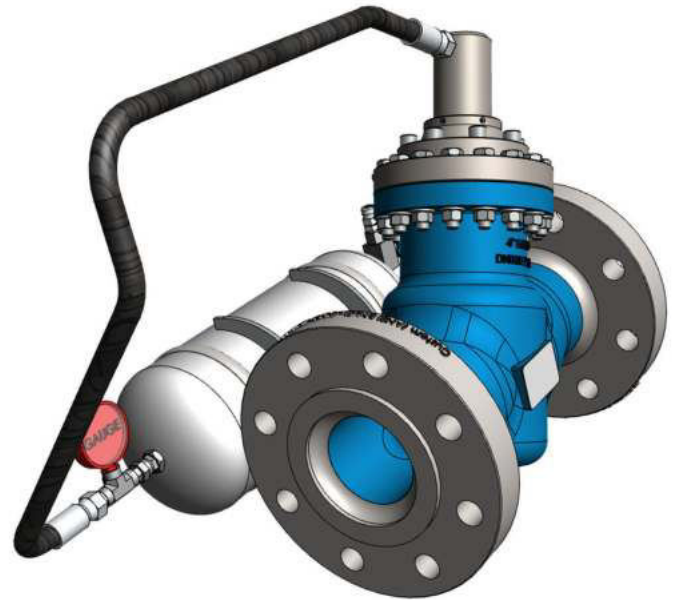

Materials Of Construction:

Part Name	Material Specification
Body - DN50 to DN100	Casting - 431 S/ Steel
Body - DN150 to DN400	Casting - BS3100 Grade A2
Body seat	431 S/ Steel
Flanges	ASTM A105
Plug	431 S/ Steel
V-Port	431 S/ Steel
Shaft	431 S/ Steel
Piston	Carbon steel clad with 309 S/ Steel or 431 S/ Steel
Plug seat - 0 to 2,5 MPa	Polyurethane
Plug seat - above 2, 5 MPa	UHMWPE
Sleeve - DN150 to DN400	431 or 304 S/Steel
Cylinder	431 S/ Steel
Cylinder holder	Carbon steel or 431 S/Steel
Seals	Polyurethane
O-Rings	Nitrile (Buna)
Nitrogen tank	Carbon steel
Hose	Double braided
Ball valve	Carbon steel with zinc coating
Charging valve	Carbon steel with zinc coating

Valve Sizing:

Please consult with Hydromine for clarification of correct sizing for your requirements.

Low Maintenance Requirement:

All the moving parts of LFC™_1B nitrogen surge relief valve are manufactured from stainless steel which increases reliability and durability. The LFC™_1B requires minimal maintenance, the majority of which, can be conducted with the valve remaining in situ.



LFC™ _1B Nitrogen Surge Relief Valve

Flow Rates:

Flow (ℓ/sec)		5	10	25	35	50	100	150	200	250	300
Pressure Drop (Kpa)	DN50	17	81								
	DN80	5	35	90							
	DN100		1.5	30	45	98					
	DN150			2.5	6.5	15	57				
	DN200					2.5	14	42	76		
	DN250						7	17	27	46	65
	DN300										
Flow US gallon / min		79.25	158.50	396.26	554.76	792.52	1585.03	2377.55	3170.06	3962.58	4755.09
Pressure Drop (psi)	2"	2.47	11.75								
	3"	0.73	5.08	13.05							
	4"		0.22	4.35	6.53	14.21					
	6"			0.36	0.94	2.18	8.27				
	8"					0.36	2.03	6.09	11.02		
	10"						1.02	2.47	3.92	6.67	9.43
	12"										

Face To Face Dimensions:

Unit	Face To Face Dimensions:								Height	
	#300		#600		#900		#1500		Centre line to Top of valve	
	(mm)	(inch)	(mm)	(inch)	(mm)	(inch)	(mm)	(inch)	(mm)	(inch)
DN50 / 2"	292	11.50	292	11.50	368	14.49	368	14.49		
DN80 / 3"	356	14.02	356	14.02	381	15.00	470	18.50		
DN100 / 4"	432	17.01	432	17.01	457	17.99	546	21.50		
DN150 / 6"	559	22.01	559	22.01	610	24.02	705	27.76		
DN200 / 8"	660	25.98	660	25.98	737	29.02	832	32.76		
DN250 / 10"	787	30.98	787	30.98	838	32.99	991	39.02		
DN300 / 12"	838	32.99	838	32.99	965	37.99	1130	44.49		
DN350 / 14"	889	35.00	889	35.00	1029	40.51	1257	49.49		
DN400 / 16"	991	39.02	991	39.02	1130	44.49	1384	54.49		

Design & Manufacturing Standards:

The LFC™ _1B nitrogen surge relief valve has been designed in accordance with various international standards as set out below:

ASME Boilers and pressure vessels design code

ANSI B16.10 ANSI B16.3

ANSI B16.34 ANSI B16.37

ANSI B16.5 ANSI N278.1

Available sizes: DN50 / 2" to DN400 / 16"

Face to face dimensions to ANSI B16.10

Pressure rating: up to 25MPa / 3 626 psi

Available end connections: ANSI B16.5, BS4504, BS10, AS/NZS 4331.1 (ISO 7005-1) DIN, all makes of grooved or ring joint couplings, HMP™ Coupling, HMP™ -TE tapered couplings and other as per clients requirement.

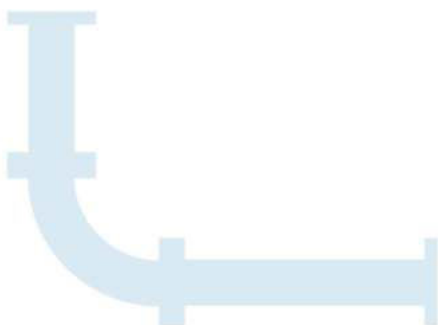



LFC™_1B Pilot Operated Surge Relief Valve

Overview:

A pilot operated surge relief valve is designed to open when an over pressure situation occurs and has an easily adjustable set pressure.

The LFC™_1B pilot operated surge relief valve has been developed to present a robust and simple and cost-effective solution to fluid handling issues in any industrial sector.

Simplicity:

The LFC™_1B pilot operated surge relief valve is designed to minimize wearing parts and in effect only has one moving part called the plug assembly. The plug assembly is a piston that is engineered to be unbalanced. The unbalanced plug is designed to use inline fluid pressure inside the valve, as well as top of the plug assembly, to keep the valve in a closed position.

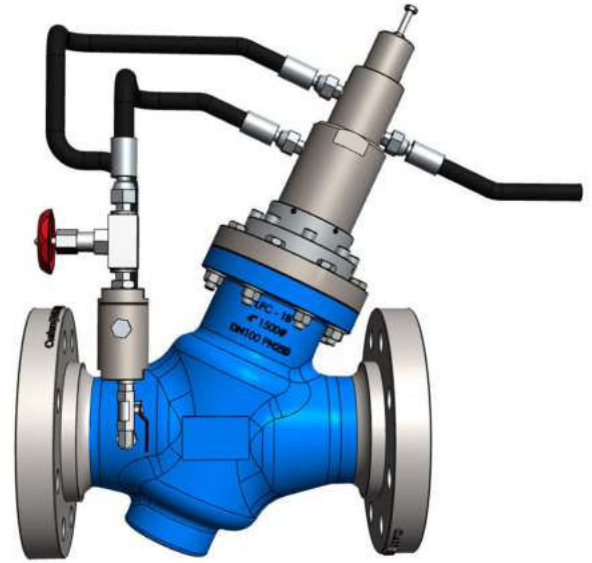

With the assistance of an external pilot the pressure on top of the plug assembly can be released and the valve will open up. Upstream pressure (P_u) would act to open the valve, the pilot releases pressure from the top of the plug assembly. As the P_u increases, the opening force increases proportionally and the pilot will release more pressure. Due to this a greater volume of water being released from the top of the plug assembly, the valve is forced to move proportionally to a greater open position. This in turn causes the valve to release more upstream pressure. If P_u is reduced, the valve will close proportionally in an effort to maintain the set pilot pressure, until normal conditions are restored.

Materials of Construction:

Part Name	Material Specification
Body - DN50 to DN100	Casting - 431 S/Steel
Body - DN150 to DN400	Casting - BS3100 Grade A2
Body seat	431 S/Steel
Flanges	ASTMA105
Plug	431 S/Steel
V-Port	431 S/Steel
Shaft	431 S/Steel
Piston	431S/ Steel
Plug seat - 0 to 2,5 MPa	Polyurethane
Plug seat - above 2,5 MPa	UHMWPE
Cylinder	431 S/Steel
Cylinder holder	Carbon steel or 431 S/Steel
Seals	Nitrile (Buna)
O-Rings	Nitrile (Buna)
Pilot	431 S/Steel
Hoses	Single braided
Ball valve	Carbon steel with zinc coating
Needle valve	316 S/Steel
Strainer	431 S/Steel

Low Maintenance Requirement:

All the moving parts of LFC™_1B surge relief valve are manufactured from stainless steel which increases reliability and durability. The LFC™_1B requires minimal maintenance, the majority of which, can be conducted with the valve remaining in situ.

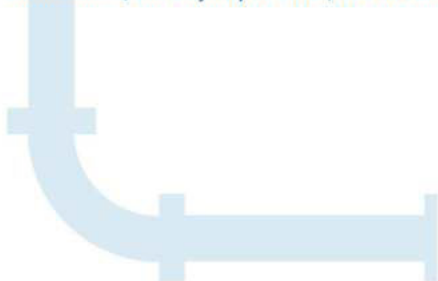



LFC™ _1B Pilot Operated Surge Relief Valve

Dimensions:

Unit	Face to face Dimensions:								Height	
	#300		#600		#900		#1500		Centre line to Top of valve	
	(mm)	(inch)	(mm)	(inch)	(mm)	(inch)	(mm)	(inch)	(mm)	(inch)
DN50 / 2"	292	11.50	292	11.50	368	14.49	368	14.49		
DN80 / 3"	356	14.02	356	14.02	381	15.00	470	18.50		
DN100 / 4"	432	17.01	432	17.01	457	17.99	546	21.50		
DN150 / 6"	559	22.01	559	22.01	610	24.02	705	27.76		
DN200 / 8"	660	25.98	660	25.98	737	29.02	832	32.76		
DN250 / 10"	787	30.98	787	30.98	838	32.99	991	39.02		
DN300 / 12"	838	32.99	838	32.99	965	37.99	1130	44.49		
DN350 / 14"	889	35.00	889	35.00	1029	40.51	1257	49.49		
DN400 / 16"	991	39.02	991	39.02	1130	44.49	1384	54.49		

Flow Rates:

Flow (ℓ/sec)	5	10	25	40	50	100	150	200	250	300
Pressure Drop (kPa)	DN50	17	81							
	DN80	5	35	90						
	DN100		1.5	30	45	98				
	DN150			2.5	6.5	15	57			
	DN200					2.5	14	42	76	
	DN250						7	17	27	46
	DN300									65
Flow US gallon/ min	79.25	158.50	396.26	634.01	792.52	1585.03	2377.55	3170.06	3962.575	4755.09
Pressure Drop (psi)	2"	2.47	11.75							
	3"	0.73	5.08	13.05						
	4"		0.22	4.35	6.53	14.21				
	6"			0.36	0.94	2.18	8.27			
	8"					0.36	2.03	6.09	11.02	
	10"						1.02	2.47	3.92	6.67
	12"									9.43

Valve Sizing:

Please consult with Hydromine for clarification of correct sizing for your requirements.

Design & Manufacturing Standards:

The LFC™ _1B pilot operated surge relief valve has been designed in accordance with various international standards as set out below:

ASME Boilers and pressure vessels design code

ANSI B16.10 ANSI B16.3

ANSI B16.34 ANSI B16.37

ANSI B16.5 ANSI N278.1

Available sizes: DN50 / 2" to DN400 / 16"

Face to face dimensions to ANSI B16.10

Pressure rating: up to 25MPa / 3 626 psi

Available end connections: ANSI B16.5, BS4504, BS10, AS/NZS 4331.1 (ISO 7005-1) DIN, all makes of grooved or ring joint couplings, HMP™ Coupling, HMP™-TE tapered couplings and other as per clients requirement.

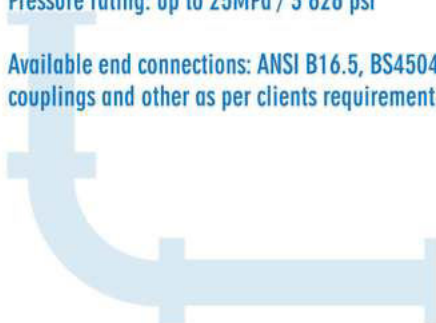



LFC™_1B Spring Acting Surge Relief Valve

Overview:

A surge relief valve is designed to open when a over pressure situation occurs and thereby prevent excessively high pressures from putting people and equipment at risk.

The LFC™_1B spring acting surge relief valve has been developed to present a robust and simple solution to fluid handling issues in the mining sector.

Simplicity:

The LFC™_1B spring acting surge relief valve is designed to minimize wearing parts and in effect only has one moving part called the plug assembly. The plug assembly is a piston that is engineered to be unbalanced. The unbalanced plug assembly together with a spring are designed to use inline fluid pressure to create specific conditions in the system without the use of an external controller or pilot.

A fixed opening force can be established by fixing the surface area ratio exposed to the upstream pressure and the spring combined. Upstream pressure (P_u) would act to open the valve. As the P_u increases, the opening force increases proportionally causing the spring to compress and the valve to open. If P_u is reduced, the valve will close proportionally in an effort to maintain its hydraulic ratio and spring force combined.

The LFC™_1B spring acting surge relief valve relief pressure, can be adjusted within the spring range.

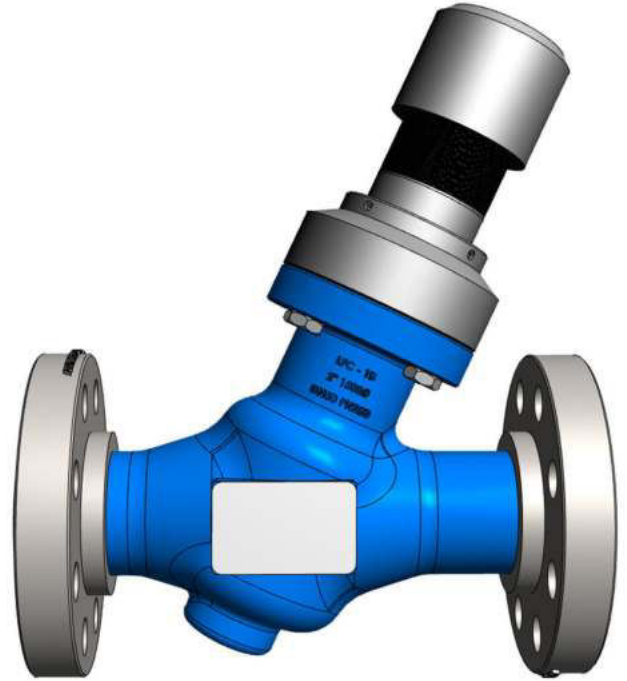

Materials Of Construction:

Part Name	Material Specification
Body - DN50 to DN100	Casting - 431 S/ Steel
Body - DN150 to DN400	Casting - BS3100 Grade A2
Body seat	431 S/ Steel
Flanges	ASTM A105
Plug	431 S/ Steel
V-Port	431 S/ Steel
Shaft	431 S/Steel
Plug seat – 0 to 2,5 MPa	Polyurethane
Plug seat - above 2, 5 MPa	UHMWPE
Cylinder	Carbon steel
Cylinder holder	431 S/Steel
Adjuster	Carbon steel
Spring holder	Carbon steel
Spring	Spring steel
Seals	Nitrile (Buna)
O-Rings	Nitrile (Buna)

Dimensions:

Unit	Face to face Dimensions:								Height	
	#300		#600		#900		#1500		Centre line to Top of valve	
	(mm)	(inch)	(mm)	(inch)	(mm)	(inch)	(mm)	(inch)	(mm)	(inch)
DN50 / 2"	292	11.50	292	11.50	368	14.49	368	14.49		
DN80 / 3"	356	14.02	356	14.02	381	15.00	470	18.50		
DN100 / 4"	432	17.01	432	17.01	457	17.99	546	21.50		
DN150 / 6"	559	22.01	559	22.01	610	24.02	705	27.76		
DN200 / 8"	660	25.98	660	25.98	737	29.02	832	32.76		
DN250 / 10"	787	30.98	787	30.98	838	32.99	991	39.02		
DN300 / 12"	838	32.99	838	32.99	965	37.99	1130	44.49		
DN350 / 14"	889	35.00	889	35.00	1029	40.51	1257	49.49		
DN400 / 16"	991	39.02	991	39.02	1130	44.49	1384	54.49		



LFC™ _1B Spring Acting Surge Relief Valve

Flow Rates:

Flow (ℓ/sec)		5	10	25	35	50	100	150	200	250	300
Pressure Drop (kPa)	DN50	17	81								
	DN80	5	35	90							
	DN100		1.5	30	45	98					
	DN150			2.5	6.5	15	57				
	DN200					2.5	14	42	76		
	DN250						7	17	27	46	65
	DN300										
Flow US gallon/ min		79.25	158.50	396.26	554.76	792.52	1585.03	2377.55	3170.06	3962.58	4755.09
Pressure Drop (psi)	2"	2.47	11.75								
	3"	0.73	5.08	13.05							
	4"		0.22	4.35	6.53	14.21					
	6"			0.36	0.94	2.18	8.27				
	8"					0.36	2.03	6.09	11.02		
	10"						1.02	2.47	3.92	6.67	9.43
	12"										

Valve Sizing:

Please consult with Hydromine for clarification of correct sizing for your requirements.

Low Maintenance Requirement:

All the moving parts of LFC™ _1B Surge relief valve are manufactured from stainless steel which increases reliability and durability. The LFC™ _1B requires minimal maintenance, the majority of which, can be conducted with the valve remaining in situ.

Design & Manufacturing Standards:

The LFC™ _1B spring acting surge relief valve has been designed in accordance with various international standards as set out below:

ASME Boilers and pressure vessels design code

ANSI B16.10 ANSI B16.3

ANSI B16.34 ANSI B16.37

ANSI B16.5 ANSI N278 .1

Available sizes: DN50 / 2" to DN400 / 16"

Face to face dimensions to ANSI B16.10

Pressure rating: up to 25MPa / 3 626 psi

Available end connections: ANSI B16.5, BS4504, BS10, AS/NZS 4331.1 (ISO 7005-1) DIN, all makes of grooved or ring joint couplings, HMP™ Coupling, HMP™ _TE tapered couplings and other as per clients requirement.

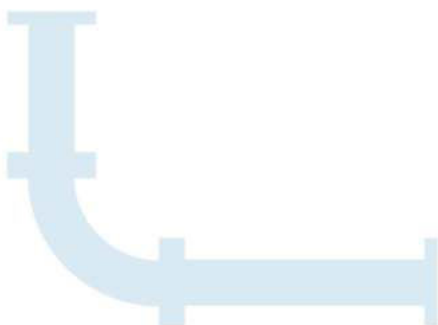



LFC™ _1B Surge Prevention Valve

Overview:

The LFC™ _1B Surge prevention system is designed to prevent water hammer or pressure surges in pumping systems. Especially in deep mining applications where water hammer is more severe due to the vertical columns. Water hammer (or, more generally, fluid hammer) is a pressure surge or wave resulting when a fluid in motion is forced to stop or change direction suddenly (Momentum Change).

Water hammer commonly occurs when a pump is stopped suddenly and a pressure wave propagates in the pipe. It is a force that can arise in any pumping system that undergoes abrupt changes in its rate of flow. These flow changes can result from pump starts and stops, the opening and closing of valves, and water column separation and closure. The piping design does have an effect upon water hammer but, we have identified the main conditions resulting in hammer.

When Does Water Hammer / Pressure Surge Occur?

Water hammer will normally occur in a pumping system when one of 3 conditions occur:

1. A total power failure, causing all the running pumps to trip.
2. The emergency stop is activated on the last running pump.
3. Tripping of the last running pump.

Water Hammer / Pressure Surge:

Typically water hammer travels at the speed of sound through its medium which can amount to 1 481 m/s (Ave 995m/s) in water. Water is only partially compressible. At ambient temperature one pound of pressure will decrease its volume by a factor of about 0.0000034. The larger the volume of water, the easier it is to see the effect of water hammer. Compression begins at the leading edge of the water column and when the additional energy it produces cannot continue on past the closed valve (Non Return valves), a pressure or shock wave is generated which travels back upstream. The inception of this shock wave is very similar to the "echo" that is produced when a sound wave, traveling through air, strikes some barrier. When the wave hits the upstream valve it is reflected back downstream but with a diminished intensity. This, back and forth, motion continues until friction and reflection losses cause the waves to dissipate. The speed at which a wave travels and the energy it loses during travel depends upon the density and compressibility of the medium in which it is traveling. It turns out that the density and compressibility of water make it a very good medium for shock wave generation and transmission.

Simplicity:

The LFC™ _1B Surge prevention valve system is designed to minimize wearing parts and in effect only has one moving part called the plug assembly. The plug assembly is a piston that is engineered to be un-balanced. The LFC™ _1B Surge prevention valve is water hydraulically actuated using an hydraulic switch. The function of the hydraulic switch is to displace water from the control chamber of the valve rapidly.

This rapid displacement of water causes the surge prevention valve to open extremely quickly. The hydraulic switch is controlled using a compact oil hydraulic power pack.

Low Maintenance Requirement:

All the moving parts of the LFC™ _1B Surge Prevention valves are manufactured from stainless steel which increases reliability and durability. The LFC™ _1B valve range requires minimal maintenance, the majority of which, can be conducted with the valve remaining in situ.

Operating Conditions:

These valves are designed to operate in systems with relatively clean media like water or other liquids with a low percentage of suspended solids and chlorides. The valve's operating pH range is 2 - 14 pH.





LFC™_1B Surge Prevention Valve

The Effects Of Water Hammer / Pressure Surge:

The graph shows the effects of water hammer on a pump station in an Mine, with an underground pump station of 770m static head when 1 pump tripped.

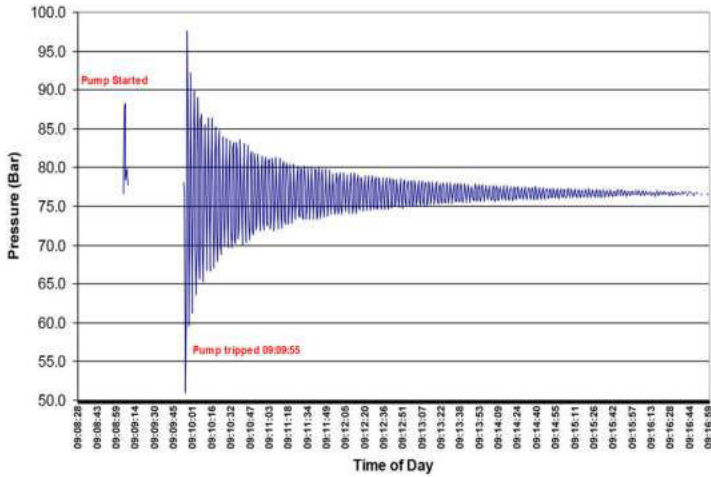

The graph shows the effects of water hammer in a Mine pump station, with an underground pump station of 786m static head when 2 pumps tripped.

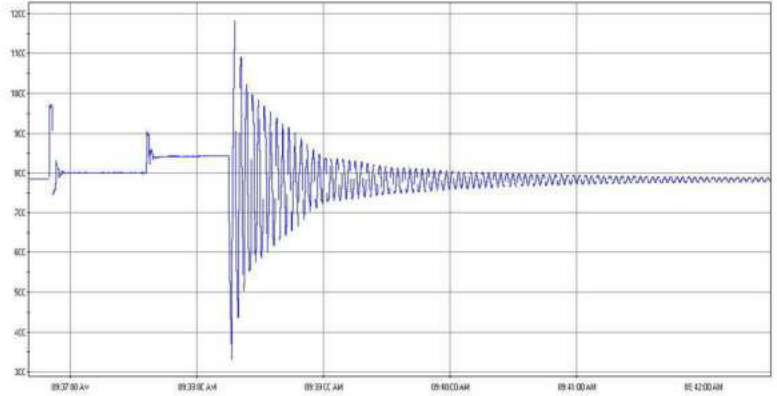

How Does It Work?

The LFC™_1B Surge prevention valve opens rapidly when there is an abrupt stop of the last running pump, or a total power failure during dewatering. At that stage the flow is still moving away from the pump station, but as soon as it loses its driving force and energy it will start returning towards the pump station. Due to the open LFC™_1B Surge prevention valve, the returning column of water is met with an open orifice and an exit point for any energy build up.

The flow moves through the surge prevention valve and energy dissipator installed after the valve. After keeping the LFC™_1B Surge prevention valve open for +/- 10 seconds, the surge prevention valve starts closing in a controlled manner to prevent any surging. The function of the energy dissipator is to discharge the flow at safe pressure and a set flow to atmosphere into the suction dam or drain.

The graph on the left shows the effects of water hammer on an underground pump station with 920m static head when 1 pump tripped. The graph on the right shows the result of using the LFC™_1B surge prevention valve system in the same pump station, when 1 pump tripped. It clearly demonstrates the effectiveness of the solution and shows that no water hammer was experienced.

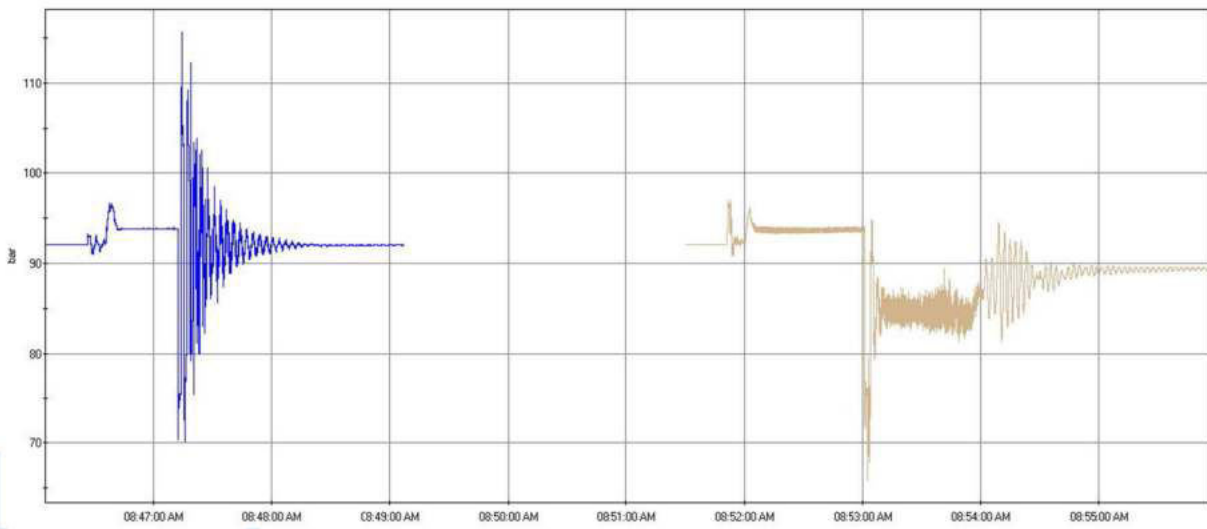
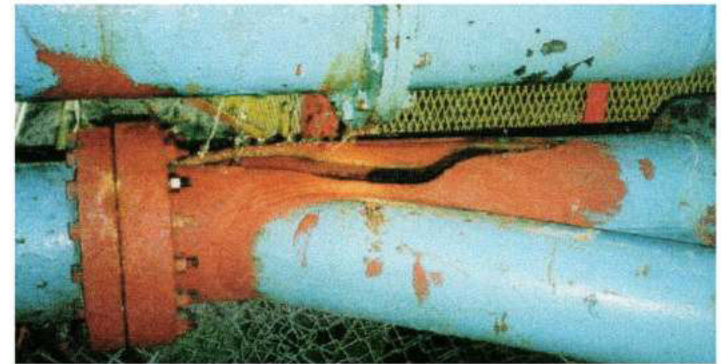



LFC™ _1B Surge Prevention Valve

LFC Surge Prevention System With Compact Oil Hydraulic Power Pack:

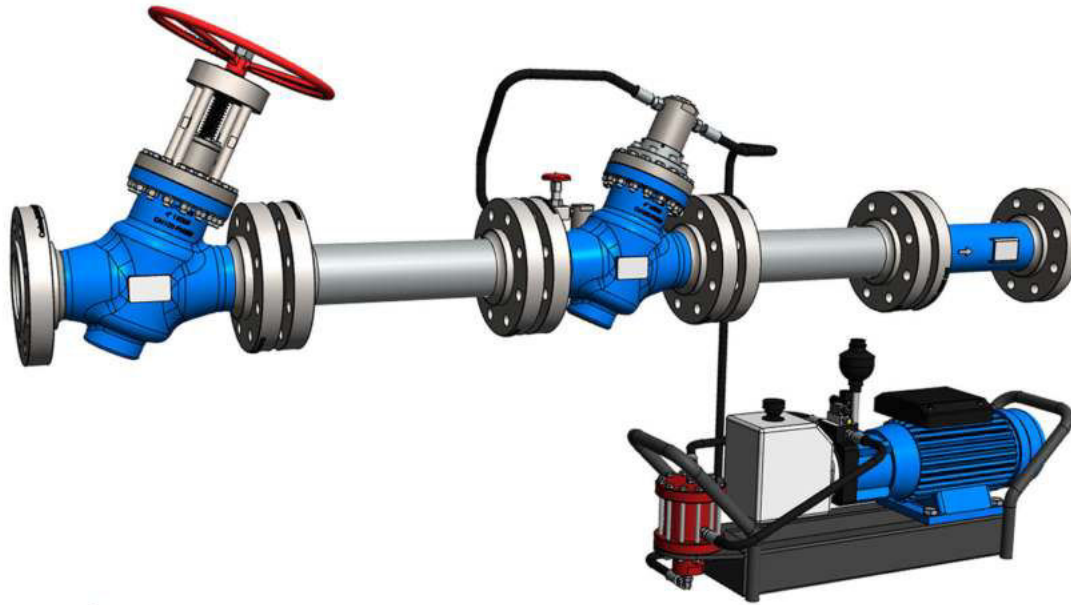

Materials Of Construction:

Part Name	Material Specification
Body- DN50 to DN100	Casting - 431 S/Steel
Body - DN150 to DN400	Casting - BS3100 Grade A2
Body seat - #1	431 S/Steel
Body seat - #2	F6
Body seat - #3	F12
Flanges	ASTM A105
Sleeve	304 S/Steel
Plug	431 S/Steel
Plug Seat	431 S/Steel
Shaft	431 S/Steel
Top cover	Carbon steel
Cylinder	431 S/Steel
Cylinder holder	Carbon steel
Piston	431 S/Steel
Seals	Polyurethane
O-Rings	Nitrile (Buna)

Dimensions:

Unit	Face to face Dimensions:								Height	
	#300		#600		#900		#1500		Centre line to Top of valve	
	(mm)	(inch)	(mm)	(inch)	(mm)	(inch)	(mm)	(inch)	(mm)	(inch)
DN50 / 2"	292	11.50	292	11.50	368	14.49	368	14.49		
DN80 / 3"	356	14.02	356	14.02	381	15.00	470	18.50		
DN100 / 4"	432	17.01	432	17.01	457	17.99	546	21.50		
DN150 / 6"	559	22.01	559	22.01	610	24.02	705	27.76		
DN200 / 8"	660	25.98	660	25.98	737	29.02	832	32.76		
DN250 / 10"	787	30.98	787	30.98	838	32.99	991	39.02		
DN300 / 12"	838	32.99	838	32.99	965	37.99	1130	44.49		
DN350 / 14"	889	35.00	889	35.00	1029	40.51	1257	49.49		
DN400 / 16"	991	39.02	991	39.02	1130	44.49	1384	54.49		



LFC™ _1B Surge Prevention Valve

Flow Rates:

Flow (ℓ/sec)		5	10	25	35	50	100	150	200	250	300
Pressure Drop (kPa)	DN50	17	81								
	DN80	5	35	90							
	DN100		1.5	30	45	98					
	DN150			2.5	6.5	15	57				
	DN200					2.5	14	42	76		
	DN250						7	17	27	46	65
Flow US gallon / min		79.25	158.50	396.26	554.76	792.52	1585.03	2377.55	3170.06	3962.58	4755.09
Pressure Drop (psi)	2"	2.47	11.75								
	3"	0.73	5.08	13.05							
	4"		0.22	4.35	6.53	14.21					
	6"			0.36	0.94	2.18	8.27				
	8"					0.36	2.03	6.09	11.02		
	10"						1.02	2.47	3.92	6.67	9.43
	12"										

Surge Prevention System:

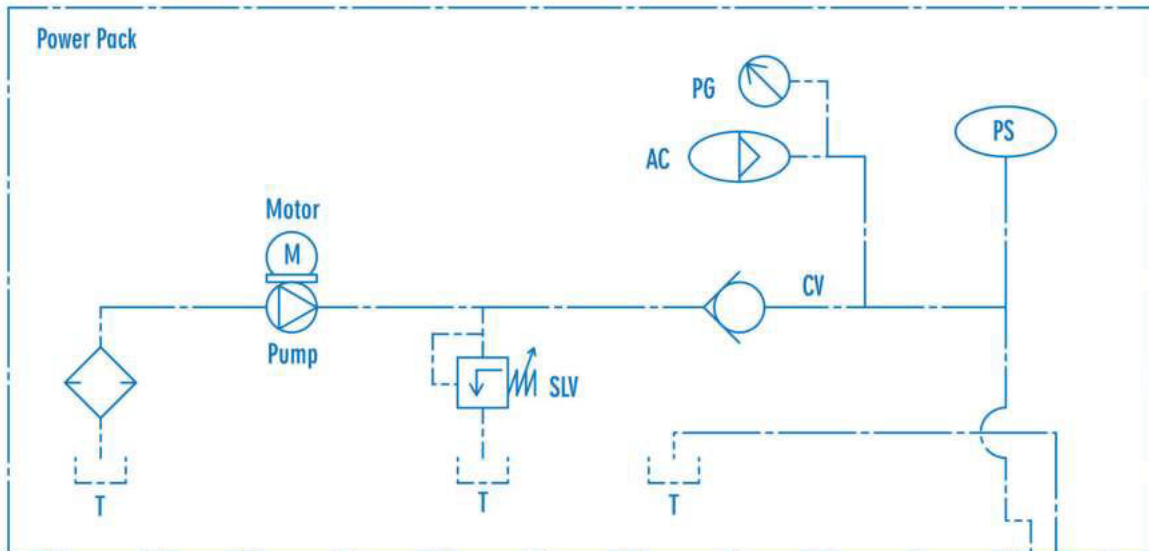

Key:

- BV – Ball Valve
- STR – STR
- NV – Needle Valve
- SV – Solenoid Valve
- AC – Accumulator
- SLV – Oil Pressure Relief Valve
- PG – Pressure Gauge
- T – Tank
- CV – Check Valve
- N/C HS – Nominally Closed Hydraulic Switch
- PS – Pressure Switch

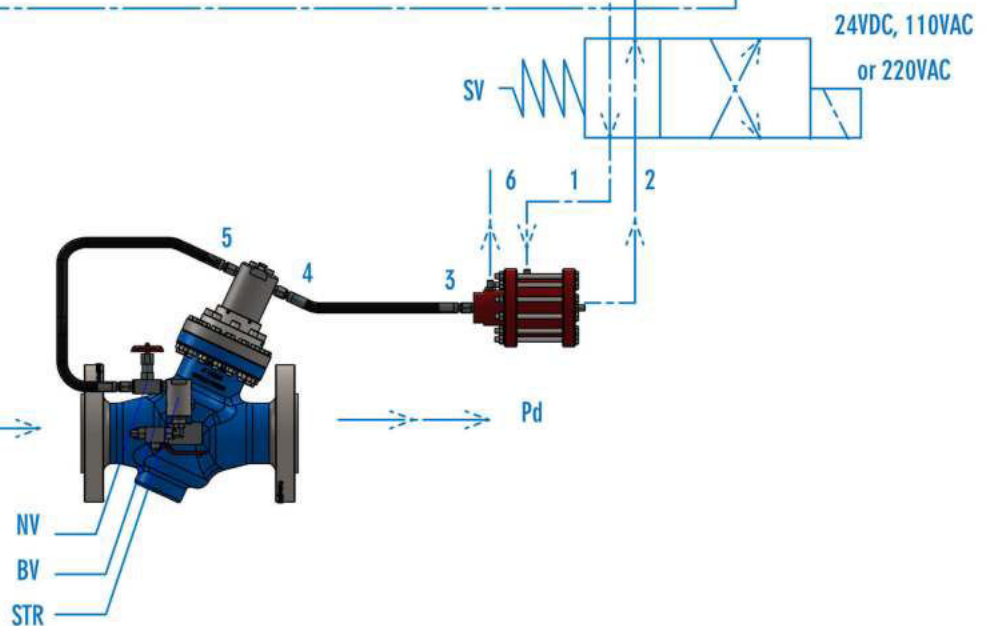
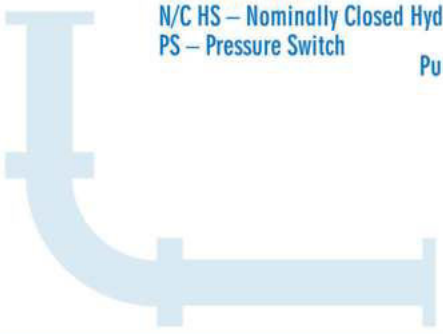



LFC™_1B Surge Prevention Valve

Typical Pump Station With Surge Prevention System.:

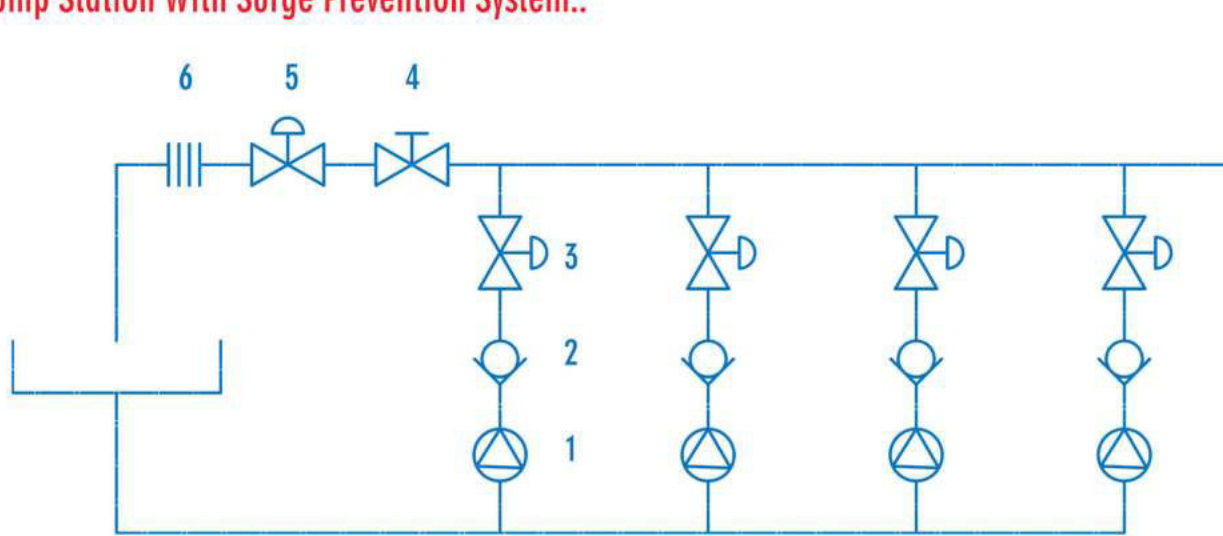

- 1 - Pump
- 2 - Check Valve
- 3 - Pump Discharge Control Valve
- 4 - Manual Isolation Valve
- 5 - Surge Prevention Valve
- 6 - Energy Dissipator

Design & Manufacturing Standards:

The LFC™_1B Surge Prevention valve has been designed in accordance with various international standards as set out below:

ASME Boilers and pressure vessels design code

ANSI B16.10 ANSI B16.3

ANSI B16.34 ANSI B16.37

ANSI B16.5 ANSI N278.1

Available sizes: DN50 / 2" to DN400 / 16"

Face to face dimensions to ANSI B16.10

Pressure rating: up to 25MPa / 3 626 psi

Available end connections: ANSI B16.5, BS4504, BSI 0, AS/NZS 4331.1 (ISO 7005-1) DIN, all makes of grooved or ring joint couplings, HMP™ Coupling, HMP™ -TE tapered couplings and other as per clients requirement.

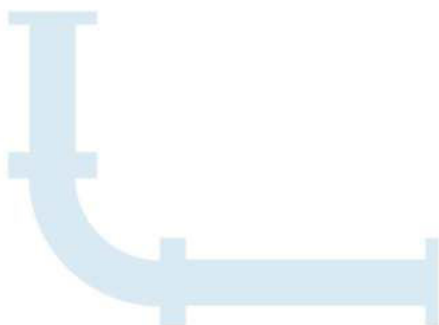



LFC™_1B Pressure Regulating Valves

Overview:

A pressure regulating valve is designed to maintain a desired downstream pressure irrespective of the flow requirement. The LFC™_1B fixed ratio pressure regulating valve has been developed to present a robust and simple solution to fluid handling issues in the mining sector.

Simplicity:

The LFC™_1B pressure regulating valve is designed to minimize wearing parts and in effect only has one moving part called the plug assembly. The plug assembly is a piston that is engineered to be unbalanced. The unbalanced plug assembly is designed to use inline fluid pressure to create specific conditions in the system without the use of an external controller or pilot. A fixed reduction ratio can be established by fixing the surface area ratio exposed to the upstream and downstream pressures. Upstream pressure (P_u) would act to open the valve and downstream pressure (P_d) would act to close the valve. As the P_d increases, the closing force increases proportionally causing the valve to close. If P_d is reduced, the valve will open proportionally in an effort to maintain its hydraulic ratio.

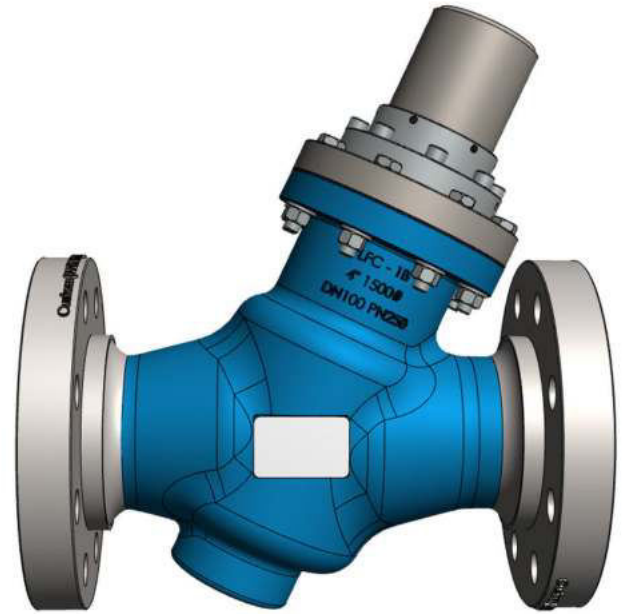

Features:

- Reduced cavitation
- Low noise levels
- Low vibration
- One moving part
- Increased flow capacity
- Long lasting

Recommended ratio limits with the V-Port design:		Recommended ratio limits with double trim designs:		Recommended ratio limits with triple trim designs:	
Maximum Ratio	Pressure (MPa)	Maximum Ratio	Pressure (MPa)	Maximum Ratio	Pressure (MPa)
5:1	0 to 2	12:1	0 to 2	12:1	2 to 4
4:1	2 to 4	9:1	2 to 4	9:1	4 to 6
3:1	4 to 6	7:1	4 to 6	6:1	6 to 8
2.5:1	6 to 8	5:1	6 to 8	5:1	8 to 10
2:1	8 to 10	4:1	8 to 10	4:1	10 to 12
1.5:1	10 to 12	3:1	10 to 12		

Selecting Control Valve With Trim Design :

Note! Only in cases where the water / fluid is free from large particles, control valves with trims can be considered. Should there be particles present in the fluid where a trim design control valve was selected, the trim will act as a strainer. Besides potentially impacting the pressure losses across the valve, this can also result in mechanical interference with the plug travel and stop the valve from operating.

Flow Rates:

Flow (ℓ/sec)		5	10	25	35	50	100	150	200	250	300
Pressure Drop (kPa)	DN50	17	81								
	DN80	5	35	90							
	DN100		1.5	30	45	98					
	DN150			2.5	6.5	15	57				
	DN200					2.5	14	42	76		
	DN250						7	17	27	46	65
	DN300										
Flow US gallon / min		79.25	158.50	396.26	554.76	792.52	1585.03	2377.55	3170.06	3962.58	4755.09
Pressure Drop (psi)	2"	2.47	11.75								
	3"	0.73	5.08	13.05							
	4"		0.22	4.35	6.53	14.21					
	6"			0.36	0.94	2.18	8.27				
	8"					0.36	2.03	6.09	11.02		
	10"						1.02	2.47	3.92	6.67	9.43
	12"										



LFC™_1B Pressure Regulating Valves

Plug Assembly, V-Port And Dealing With Cavitation:

Closed Position

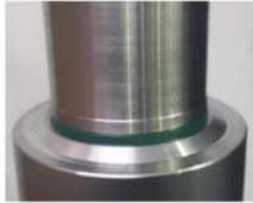

5% Open Position

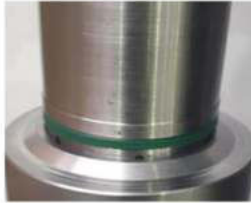

12% Open Position

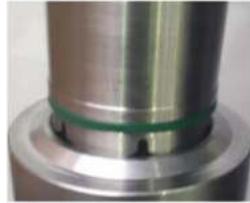

30% Open Position

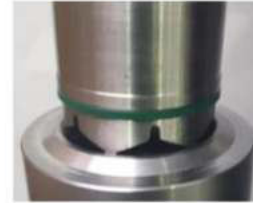

40% Open Position

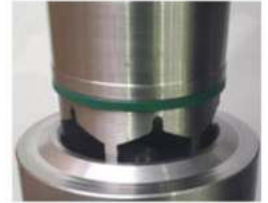

As displayed, the LFC™_1B pressure regulating valve plug assembly and movements.

Closed Position: Shows the plug assembly on the body seat in a fully closed valve position.

5% Open Position: Shows the plug assembly in a 5% open position. It can clearly be seen that only the top of the V-Port opens up and creates a flow path. This reduces cavitation and helps with fine control at low flow conditions.

12% Open Position: Shows the plug assembly in the 12% open position. Now it can be observed how the V-Port moved away from the seat and the openings are increasing proportionally. At this point the top of the V-Ports are now being exposed to the flow path.

30% Open Position: Shows the plug assembly in the 30% opened position. Now it can clearly be seen that the full V-Port is creating a larger orifice in the flow path. Up to this point, cavitation needs to be dealt with to increase the life expectancy of the valve. The V-port trim ensures that the seating elements are further apart from each other during low flow allowing the cavitation to take place on noncritical components of the valve.

40% Open Position: Shows the plug assembly in the 40% open position. Now it can clearly be seen that the V-Port is completely away from the seat and the flow path is now relatively large. At this point the flow is approaching its medium demand flow rate and the V-Port has little to no function.

Materials Of Construction:

Part Name	Material Specification
Body - DN50 to DN100	Casting - 431 S/ Steel
Body - DN150 to DN400	Casting - BS3100 Grade A2
Body seat	431 S/ Steel
Flanges	ASTM A105
Plug	431 S/ Steel
V-Port	431 S/ Steel
Trim	431 S/Steel
Piston rod	431 S/Steel
Piston	431 S/ Steel
Plug seat – 0 to 2,5 MPa	Polyurethane
Plug seat - above 2, 5 MPa	UHMWPE
Sleeve (DN150 to DN400)	431 or 304 S/Steel
Cylinder	431 S/ Steel
Cylinder holder	Carbon steel
Seals	Nitrile (Buna)
O-Rings	Nitrile (Buna)
Hose	Single braided

Low Maintenance Requirement:

All the moving parts of LFC™_1B pressure control valve are manufactured from stainless steel which increases reliability and durability. The LFC™_1B pressure control valve requires minimal maintenance, the majority of which, can be conducted with the valve remaining in situ.



LFC™ _1B Pressure Regulating Valves

Robust, Reliable and Efficient:

Due to the minimal number of moving parts to effect the fluid control, the number of potential failures are minimized. The valve can only fail for the following reasons:

- 1. Lack of maintenance:** If filters are utilized in the control system, regular cleaning of the filters are required to prevent the valve operation from slowing down and eventually creating a possible hydraulic locking of the valve. This process depends on the condition of the service water being used. The dirtier the water, the shorter the filter maintenance intervals will need to be. A valve seal replacement program should be employed to ensure that the valves plug seals are replaced in accordance with manufacturer's recommendations. As these seals are largely protected the intervals for maintenance on these items can usually be done in terms of years. If these seals fail, the valve will start to bypass pressure from the Pu to the air vent chamber. Valves are equipped with tell-tale breather holes which will immediately indicate seal failure.
- 2. Mechanical fouling:** Should a large object be introduced into the service water piping and reach the valve inlet, such object could create a mechanical jam and prevent the plug from operating.
- 3. Overriding of the control system:** As the valve is hydraulically actuated and controlled, if the control system is isolated from the service water by way of isolation valves in the control system, the valve will be hydraulically locked in position and will be unable to adjust to the inline condition changes.
- 4. Mechanical failure of the main seating arrangement:** In time, the seating arrangement will experience conditions of high velocity across the seating surface during low flow conditions. The high velocity will eventually cause wear on the seating surface and on the plug seating surface. If the valves starts to bypass across its seat, the downstream pressure could increase to the point where the pressure relief valve is activated during low flow conditions.

All of these conditions are easily avoidable and rectifiable through regular maintenance programs and service water quality control and condition monitoring.

Dimensions:

Unit	Face to face Dimensions:								Height	
	#300		#600		#900		#1500		Centre line to top of valve	
	(mm)	(inch)	(mm)	(inch)	(mm)	(inch)	(mm)	(inch)	(mm)	(inch)
DN50 / 2"	292	11.50	292	11.50	368	14.49	368	14.49		
DN80 / 3"	356	14.02	356	14.02	381	15.00	470	18.50		
DN100 / 4"	432	17.01	432	17.01	457	17.99	546	21.50		
DN150 / 6"	559	22.01	559	22.01	610	24.02	705	27.76		
DN200 / 8"	660	25.98	660	25.98	737	29.02	832	32.76		
DN250 / 10"	787	30.98	787	30.98	838	32.99	991	39.02		
DN300 / 12"	838	32.99	838	32.99	965	37.99	1130	44.49		
DN350 / 14"	889	35.00	889	35.00	1029	40.51	1257	49.49		
DN400 / 16"	991	39.02	991	39.02	1130	44.49	1384	54.49		

Valve Sizing:

Please consult with Hydromine for clarification of correct sizing for your requirements.

Design & Manufacturing Standards:

The LFC™ _1B pressure regulating valve has been designed in accordance with various international standards as set out below:

ASME Boilers and pressure vessels design code

ANSI B16.10 ANSI B16.3

ANSI B16.34 ANSI B16.37

ANSI B16.5 ANSI N278 .1

Available sizes: DN50 / 2" to DN400 / 16"

Face to face dimensions to ANSI B16.10

Pressure rating: up to 25MPa / 3 626 psi

Available end connections: ANSI B16.5, BS4504, BS10, AS/NZS 4331.1 (ISO 7005-1) DIN, all makes of grooved or ring joint couplings, HMP™ Couplings, HMP™ -TE tapered couplings and other as per clients requirement.



LFC™ _1B Pressure Control Valves

Overview:

A pressure control valve is designed to maintain a desired downstream pressure irrespective of the flow requirement. The LFC™ _1B pressure control valve is fitted with a modulating intelligent electrical actuator. Any make of electrical actuator can be fitted to the pressure control valve. The LFC™ _1B pressure control valve has been developed to present a robust and simple solution to fluid handling issues in any industrial sector.

Simplicity:

The LFC™ pressure control valve is designed to offer increased efficiency and accuracy as well as improve on ease of maintenance and in effect only has one moving part called the plug. The plug is a piston that is engineered to be balanced. The balanced plug enables easy opening and closing at any pressure and differential condition. The differential pressures do not affect the operating torque which results in a relatively flat torque curve allowing for the fitment of smaller actuators.

Features:

- Reduced cavitation
- Low noise levels
- Low vibration
- One moving part
- Long lasting

Robust, Reliable & Efficient:

Due to the minimal number of moving parts to effect the fluid control, the number of potential failures are minimized.



Recommended ratio limits with the V-Port design:		Recommended ratio limits with double trim designs:		Recommended ratio limits with triple trim designs:	
Maximum Ratio	Pressure (MPa)	Maximum Ratio	Pressure (MPa)	Maximum Ratio	Pressure (MPa)
5:1	0 to 2	12:1	0 to 2	12:1	2 to 4
4:1	2 to 4	9:1	2 to 4	9:1	4 to 6
3:1	4 to 6	7:1	4 to 6	6:1	6 to 8
2.5:1	6 to 8	5:1	6 to 8	5:1	8 to 10
2:1	8 to 10	4:1	8 to 10	4:1	10 to 12
1.5:1	10 to 12	3:1	10 to 12		

Selecting Control Valve With Trim Design :

Note! Only in cases where the water / fluid is free from large particles, control valves with trims can be considered. Should there be particles present in the fluid where a trim design control valve was selected, the trim will act as a strainer. Besides potentially impacting the pressure losses across the valve, this can also result in mechanical interference with the plug travel and stop the valve from operating.

Flow Rates:

Flow (ℓ/sec)	5	10	25	35	50	100	150	200	250	300
Pressure Drop (kPa)	DN50	17	81							
	DN80	5	35	90						
	DN100		1.5	30	45	98				
	DN150			2.5	6.5	15	57			
	DN200					2.5	14	42	76	
	DN250						7	17	27	46
	DN300									65
Flow US gallon / min	79.25	158.50	396.26	554.76	792.52	1585.03	2377.55	3170.06	3962.58	4755.09
Pressure Drop (psi)	2"	2.47	11.75							
	3"	0.73	5.08	13.05						
	4"		0.22	4.35	6.53	14.21				
	6"			0.36	0.94	2.18	8.27			
	8"					0.36	2.03	6.09	11.02	
	10"						1.02	2.47	3.92	6.67
	12"									9.43



LFC™_1B Pressure Control Valves

Plug Assembly, V-Port And Dealing With Cavitation:

Closed Position

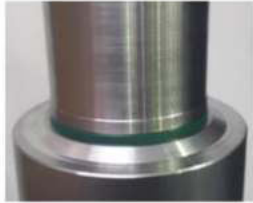

5% Open Position

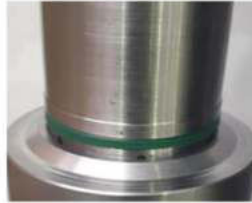

12% Open Position

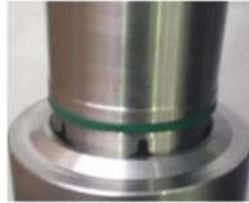

30% Open Position



40% Open Position

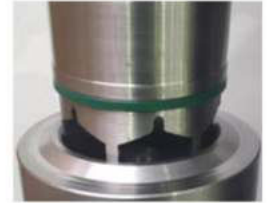

As displayed, the LFC™_1B pressure control valve plug assembly and movements.

Closed Position: Shows the plug assembly on the body seat in a fully closed valve position.

5% Open Position: Shows the plug assembly in a 5% open position. It can clearly be seen that only the top of the V-Port opens up and creates a flow path. This reduces cavitation and helps with fine control at low flow conditions.

12% Open Position: Shows the plug assembly in the 12% open position. Now it can be observed how the V-Port moved away from the seat and the openings are increasing proportionally. At this point the top of the V-Ports are now being exposed to the flow path.

30% Open Position: Shows the plug assembly in the 30% opened position. Now it can clearly be seen that the full V-Port is creating a larger orifice in the flow path. Up to this point, cavitation needs to be dealt with to increase the life expectancy of the valve. The V-port trim ensures that the seating elements are further apart from each other during low flow allowing the cavitation to take place on noncritical components of the valve.

40% Open Position: Shows the plug assembly in the 40% open position. Now it can clearly be seen that the V-Port is completely away from the seat and the flow path is now relatively large. At this point the flow is approaching its medium demand flow rate and the V-Port has little to no function.

Materials Of Construction:

Part Name	Material Specification
Body - DN50 to DN100	Casting - 431 S/ Steel
Body - DN150 to DN400	Casting - BS3100 Grade A2
Body seat	431 S/ Steel
Flanges	ASTM A105
Plug	431 S/ Steel
V-Port	431 S/ Steel
Trim	431 S/Steel
Spindle / Shaft	431 S/Steel
Plug seat – 0 to 2,5 MPa	Polyurethane
Plug seat - above 2, 5 MPa	UHMWPE
Sleeve (DN150 to DN400)	431 or 304 S/Steel
Top Cover	Carbon steel
Seals	Nitrile (Buna)
Tripod rods	Carbon steel
Bush holder	Carbon steel
Plug seals	Polyurethane
Shaft seal	Polyurethane
Wiper seal	Polyurethane
O-Rings	Nitrile (Buna)

Low Maintenance Requirement:

All the moving parts of LFC™_1B pressure control valve are manufactured from stainless steel which increases reliability and durability. The LFC™_1B pressure control valve requires minimal maintenance, the majority of which, can be conducted with the valve remaining in situ.



LFC™ _1B Pressure Control Valves

Dimensions:

Unit	Face to face Dimensions:								Height	
	#300		#600		#900		#1500		Centre line to top of valve	
	(mm)	(inch)	(mm)	(inch)	(mm)	(inch)	(mm)	(inch)	(mm)	(inch)
DN50 / 2"	292	11.50	292	11.50	368	14.49	368	14.49		
DN80 / 3"	356	14.02	356	14.02	381	15.00	470	18.50		
DN100 / 4"	432	17.01	432	17.01	457	17.99	546	21.50		
DN150 / 6"	559	22.01	559	22.01	610	24.02	705	27.76		
DN200 / 8"	660	25.98	660	25.98	737	29.02	832	32.76		
DN250 / 10"	787	30.98	787	30.98	838	32.99	991	39.02		
DN300 / 12"	838	32.99	838	32.99	965	37.99	1130	44.49		
DN350 / 14"	889	35.00	889	35.00	1029	40.51	1257	49.49		
DN400 / 16"	991	39.02	991	39.02	1130	44.49	1384	54.49		

Valve Sizing:

Please consult with Hydromine for clarification of correct sizing for your requirements.

Design & Manufacturing Standards:

The LFC™ _1B Pressure control valve has been designed in accordance with various international standards as set out below:

ASME Boilers and pressure vessels design code

ANSI B16.10 ANSI B16.3

ANSI B16.34 ANSI B16.37

ANSI B16.5 ANSI N278 .1

Available sizes: DN50 / 2" to DN400 / 16"

Face to face dimensions to ANSI B16.10

Pressure rating: up to 25MPa / 3 626 psi

Available end connections: ANSI B16.5, BS4504, BS10, AS/NZS 4331.1 (ISO 7005-1) DIN, all makes of grooved or ring joint couplings, HMP™ Couplings, HMP™ -TE tapered couplings and other as per clients requirement.

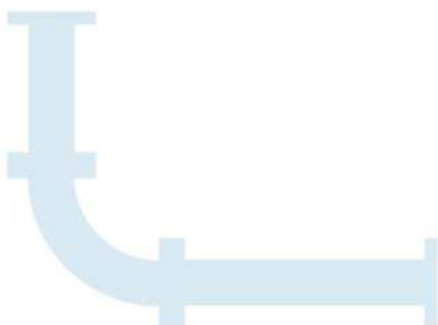



LFC™ _1B Water Hydraulic Actuated Isolation Valves

Overview:

The LFC™ _1B Water hydraulic actuated isolation valves is based on the same design as the LFC™ _1B pressure regulating valve. Water hydraulic actuated valves are more cost effective than the LFC™ _1B electrical actuated valves. The upstream water hydraulic power are used to actuate the LFC™ _1B isolation valve. The speed of the valve can be adjusted to any desired speed fairly quickly and easily.

The LFC™ _1B Water hydraulic actuated isolation valve are generally used for remote isolation, dissipator isolation/ level control valves. Using line fluids removes the need for any gearboxes or handwheels which makes them ideal for applications where tampering is a problem.

Low Operating Torque:

The LFC™ _1B Water hydraulic isolation valves are hydrostatically un-balanced to enable easy opening and closing at any pressure and differential conditions. It does not require the use of a gearbox or a by-pass valve to balance pressure between the inlet and outlet.

Operating Conditions:

These valves are designed to operate in systems with relatively clean media like water or other liquids with a low percentage of suspended solids and chlorides. The valve's operating pH range is 2 - 14 pH.

Simplicity:

The LFC™ _1B Water hydraulic valve is designed to minimize wearing parts and in effect only has one moving part called the plug assembly. The plug assembly is a piston that is engineered to be un-balanced. The un-balanced plug uses the inline fluid pressure to remove the influence of differential pressure on operating torque. As such, the valve operating torque is the torque required to overcome the sum of the friction forces generated between the valve body, seals and the cylinder plus the weight of the plug (depending on the installation configuration). This torque requirement is not affected by inline pressure variants and therefore makes these valves extremely good for actuation applications as well as for isolation valves where manual operation is required. Removal of gearboxes reduces maintenance requirements and improves troubleshooting times. The water hydraulic actuators/ control panels are simple in comparison with an electrical actuator. The LFC™ _1B Water hydraulic valve can easily be fitted with limit switches to give open and closed indication.

Materials of Construction:

Part Name	Material Specification
Body - DN50 to DN150	Casting - 431 S/ Steel
Body - DN200 to DN400	Casting - BS3100 Grade A2
Body seat	431 S/ Steel
Flanges	ASTM A105
Plug	431 S/ Steel
V-Port	431 S/ Steel
Shaft	431 S/Steel
Piston	431 S/ Steel
Plug seat - 0 to 2,5 MPa	Polyurethane
Plug seat - 2.5 to 4 MPa	UHMWPE
Plug seat - above 4 MPa	431 S/ Steel
Cylinder	304 or 431 S/ Steel
Cylinder holder	Carbon steel or 431 S/Steel
Cylinder cover	Carbon steel
Limit switch rod	431 S/ Steel
Limit switch bracket	Carbon steel
Seals	Polyurethane
O-Rings	Nitrile (Buna)
Hoses	Single braided

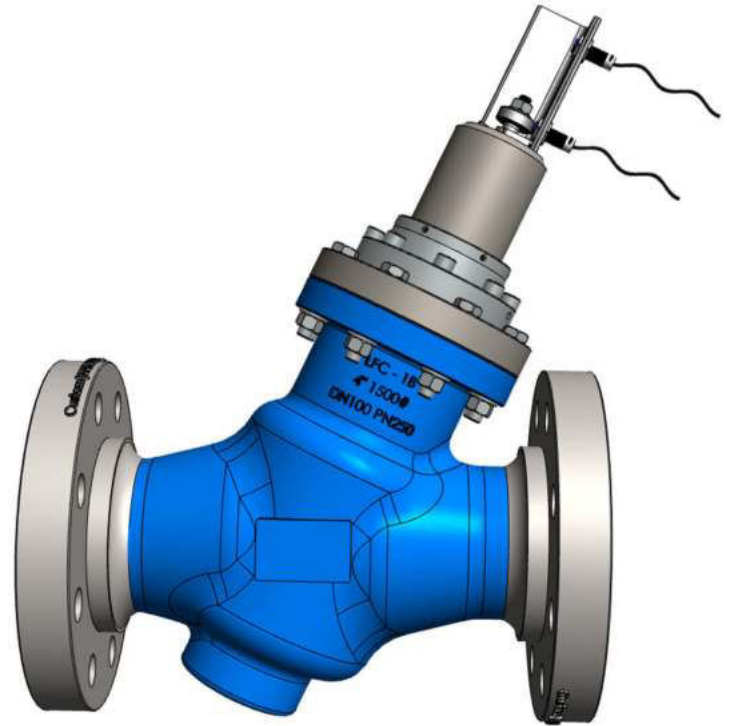



LFC™ _1B Water Hydraulic Actuated Isolation Valves

Flow Rates:

Flow (ℓ/sec)		5	10	25	35	50	100	150	200	250	300
Pressure Drop (kPa)	DN50	17	81								
	DN80	5	35	90							
	DN100		1.5	30	45	98					
	DN150			2.5	6.5	15	57				
	DN200					2.5	14	42	76		
	DN250						7	17	27	46	65
	DN300										
Flow US gallon/ min		79.25	158.50	396.26	554.76	792.52	1585.03	2377.55	3170.06	3962.58	4755.09
Pressure Drop (psi)	2"	2.47	11.75								
	3"	0.73	5.08	13.05							
	4"		0.22	4.35	6.53	14.21					
	6"			0.36	0.94	2.18	8.27				
	8"					0.36	2.03	6.09	11.02		
	10"						1.02	2.47	3.92	6.67	9.43
	12"										

Valve Sizing:

Please consult with Hydromine for clarification of correct sizing for your requirements.

LFC_1B Water Hydraulic Actuated Valve With Control Panel And Limit Switches:

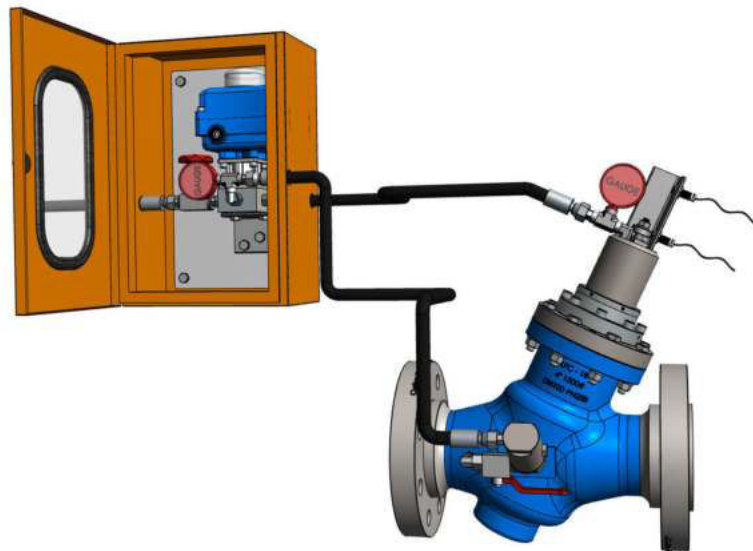

Dimensions:

Unit	Face to face Dimensions:							
	#300		#600		#900		#1500	
	(mm)	(inch)	(mm)	(inch)	(mm)	(inch)	(mm)	(inch)
DN50 / 2"	292	11.50	292	11.50	368	14.49	368	14.49
DN80 / 3"	356	14.02	356	14.02	381	15.00	470	18.50
DN100 / 4"	432	17.01	432	17.01	457	17.99	546	21.50
DN150 / 6"	559	22.01	559	22.01	610	24.02	705	27.76
DN200 / 8"	660	25.98	660	25.98	737	29.02	832	32.76
DN250 / 10"	787	30.98	787	30.98	838	32.99	991	39.02
DN300 / 12"	838	32.99	838	32.99	965	37.99	1130	44.49
DN350 / 14"	889	35.00	889	35.00	1029	40.51	1257	49.49
DN400 / 16"	991	39.02	991	39.02	1130	44.49	1384	54.49



LFC™ _1B Water Hydraulic Actuated Isolation Valves

Low Maintenance Requirement:

All the moving parts of the LFC™ _1B water hydraulic actuated isolation valves are manufactured from stainless steel which increases reliability and durability. The LFC™ _1B requires minimal maintenance, the majority of which, can be conducted with the valve remaining in situ.

Design & Manufacturing Standards:

The LFC™ _1B water hydraulic actuated isolation valve has been designed in accordance with various international standards as set out below:

ASME Boilers and pressure vessels design code

ANSI B16.10 ANSI B16.3

ANSI B16.34 ANSI B16.37

ANSI B16.5 ANSI N278 .1

Available sizes: DN50 / 2" to DN400 / 16"

Pressure rating: up to 25MPa / 3 626 psi

Face to face dimensions: ANSI B16.10 or other

Available end connections: ANSI B16.5, BS4504, BS10, AS/NZS 4331.1 (ISO 7005-1) DIN, all makes of grooved or ring joint couplings, HMP™ Coupling, HMP™ -TE tapered couplings and other as per clients requirement.

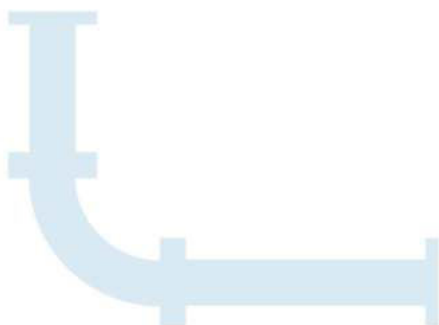



LFC™_3B Pilot Operated Surge Relief Valve

Overview:

A pilot operated surge relief valve is designed to open when an over pressure situation occurs and has an easily adjustable set pressure.

The LFC™_3B pilot operated surge relief valve has been developed to present a robust and simple and cost-effective low pressure (up to 2.5 MPa / 363 Psi) solution to fluid handling issues in any industrial sector.

Simplicity:

The LFC™_3B pilot operated surge relief valve is designed to minimize wearing parts and in effect only has one moving part called the plug assembly. The plug assembly is a piston that is engineered to be unbalanced. The unbalanced plug is designed to use inline fluid pressure in side the valve, as well as top of the plug assembly, to keep the valve in a closed position.

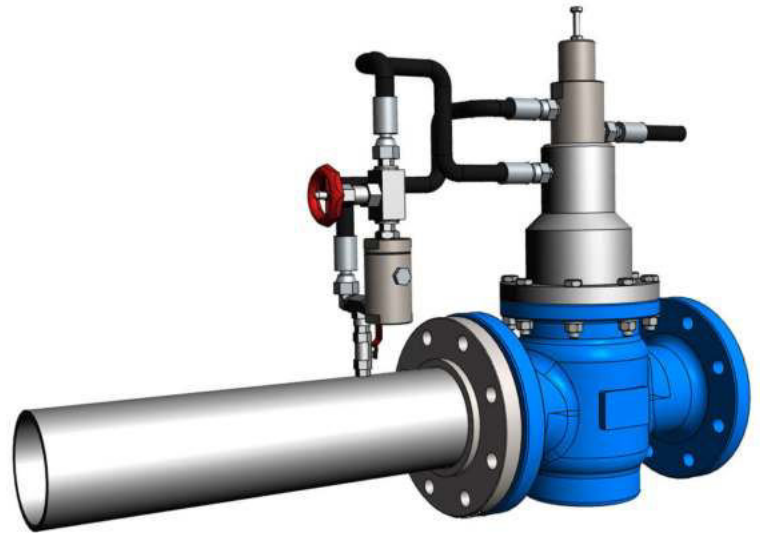

With the assistance of an external pilot the pressure on top of the plug assembly can be released and the valve will open up. Upstream pressure (Pu) would act to open the valve, the pilot releases pressure from the top of the plug assembly. As the Pu increases, the opening force increases proportionally and the pilot will release more pressure. Due to this a greater volume of water being released from the top of the plug assembly, the valve is forced to move proportionally to a greater open position. This in turn causes the valve to release more upstream pressure. If Pu is reduced, the valve will close proportionally in an effort to maintain the set pilot pressure, until normal conditions are restored.

Materials of Construction & Dimensions:

Part Name	Material Specification	Face To Face Dimensions		
		Valve size	Face to face #150	
		Unit	(mm)	(Inch)
Body	Casting - Ductile iron			
Body seat	431 / 304 S/Steel			
Plug	431 / 304 S/Steel	DN50 / 2"	203	7.99
V-Port	431 / 304 S/Steel	DN80 / 3"	241	9.49
Shaft	431 / 304 S/Steel	DN100 / 4"	292	11.50
Piston	431 / 304 S/Steel	DN150 / 6"	356	14.02
Plug seat	Polyurethane	DN200 / 8"	495	19.49
Sleeve	431 / 304 S/Steel	DN250 / 10"	622	24.49
Sleeve holder	Ductile iron	DN300 / 12"	699	27.52
Cylinder	431 / 304 S/Steel	DN350 / 14"	787	30.98
Pilot	431 / 304 S/Steel	DN400 / 16"	914	35.98
Strainer	431 / 304 S/Steel			
Needle valve	316 S/Steel			
Hoses	Single braided wire hose			
O-Rings	Nitrile (Buna)			

Low Maintenance Requirement:

All the moving parts of LFC™_3B surge relief valve are manufactured from stainless steel which increases reliability and durability. The LFC™_3B requires minimal maintenance, the majority of which, can be conducted with the valve remaining in situ.

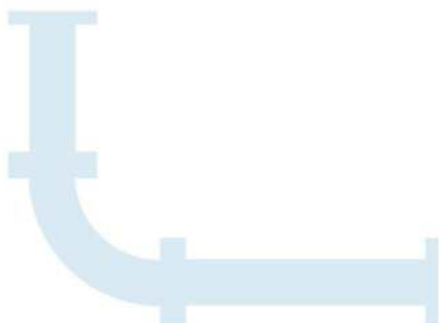



LFC™_3B Pilot Operated Surge Relief Valve

Flow Rates:

Flow (ℓ/sec)		5	10	25	40	50	100	150	200	250	300	350	400
Pressure Drop (kPa)	DN50	47	94										
	DN80	17	34	86									
	DN100		23	57	79								
	DN150			26	36	51	102						
	DN200					28	56	84	112				
	DN250						37	55	73	91	112		
	DN300						26	37	50	63	75	90	103
Flow US gallon/ min		79.25	158.50	396.26	634.01	792.52	1585.03	2377.55	3170.06	3962.575	4755.09	5547.605	6340.12
Pressure Drop (psi)	2"	6,82	13,63										
	3"	2,47	4,93	12,47									
	4"		3,34	8,27	11,46								
	6"			3,77	5,22	7,4	14,79						
	8"					4,06	8,12	12,18	16,24				
	10"						5,37	7,98	10,59	13,2	16,24		
	12"						3,77	5,37	7,25	9,14	10,88	13,05	14,96

Valve Sizing:

Please consult with Hydromine for clarification of correct sizing for your requirements.

Design & Manufacturing Standards:

The LFC™_3B pilot operated surge relief valve has been designed in accordance with various international standards as set out below:

ASME Boilers and pressure vessels design code

ANSI B16.10 ANSI B16.3

ANSI B16.34 ANSI B16.37

ANSI B16.5 ANSI N278.1

Available sizes: DN50 / 2" to DN400 / 16"

Face to face dimensions to ANSI B16.10

Pressure rating: up to 2.5 MPa / 363psi

Available end connections: ANSI B16.5, BS4504, BS10, AS/NZS 4331.1 (ISO 7005-1) DIN, all makes of grooved or ring joint couplings and other as per client's requirement.

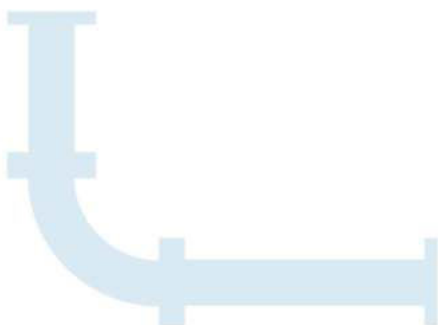



LFC™ _3B Spring Acting Surge Relief Valve

Overview:

A surge relief valve is designed to open when a over pressure situation occurs and thereby prevent excessively high pressures from putting people and equipment at risk.

The LFC™ _3B spring acting surge relief valve has been developed to present a robust and simple and cost effective low pressure (up to 2.5 MPa / 363 Psi) solution to fluid handling issues in any industrial sector.

Simplicity:

The LFC™ _3B spring acting surge relief valve is designed to minimize wearing parts and in effect only has one moving part called the plug assembly. The plug assembly is a piston that is engineered to be unbalanced. The unbalanced plug assembly together with a spring are designed to use inline fluid pressure to create specific conditions in the system without the use of an external controller or pilot.

A fixed opening force can be established by fixing the surface area ratio exposed to the upstream pressure and the spring combined. Upstream pressure (P_u) would act to open the valve. As the P_u increases, the opening force increases proportionally causing the spring to compress and the valve to open. If P_u is reduced, the valve will close proportionally in an effort to maintain its hydraulic ratio and spring force combined.

The LFC™ _3B spring acting surge relief valve relief pressure can be adjusted within the spring range.

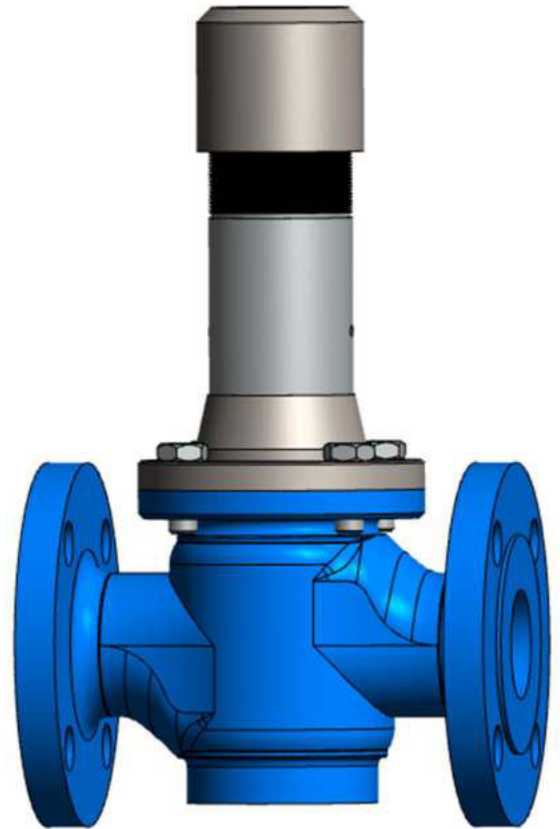

Materials Of Construction & Dimensions:

Part Name	Material Specification	Face To Face Dimensions		
		Valve size	Face To face #150	
		Unit	(mm)	(Inch)
Body	Casting - Ductile iron			
Body seat	431 / 304 S/ Steel			
Plug	431 / 304 S/ Steel	DN50 / 2"	203	7.99
V-Port	431 / 304 S/ Steel	DN80 / 3"	241	9.49
Shaft	431 / 304 S/ Steel	DN100 / 4"	292	11.50
Piston	431 / 304 S/ Steel	DN150 / 6"	356	14.02
Plug seat	Polyurethane	DN200 / 8"	495	19.49
Sleeve	431 / 304 S/ Steel	DN250 / 10"	622	24.49
Sleeve Holder	Ductile iron	DN300 / 12"	699	27.52
Cylinder	Carbon steel	DN350 / 14"	787	30.98
Cylinder holder	Ductile iron	DN400 / 16"	914	35.98
Adjuster	Carbon steel			
Spring holder	Carbon steel			
Spring	Spring steel			
O-Rings	Nitrile (Buna)			

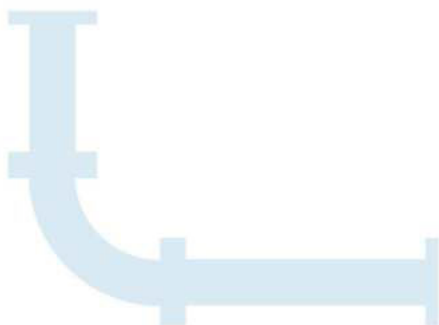



LFC™ _3B Spring Acting Surge Relief Valve

Flow Rates:

Flow (l/sec)	5	10	25	40	50	100	150	200	250	300	350	400
Pressure Drop (kPa)	DN50	47	94									
	DN80	17	34	86								
	DN100		23	57	79							
	DN150			26	36	51	102					
	DN200					28	56	84	112			
	DN250						37	55	73	91	112	
	DN300						26	37	50	63	75	90
Flow US gallon/ min	79.25	158.50	396.26	634.01	792.52	1585.03	2377.55	3170.06	3962.575	4755.09	5547.605	6340.12
Pressure Drop (psi)	2"	6.82	13.63									
	3"	2.47	4.93	12.47								
	4"		3.34	8.27	11.46							
	6"			3.77	5.22	7.4	14.79					
	8"					4.06	8.12	12.18	16.24			
	10"						5.37	7.98	10.59	13.2	16.24	
	12"						3.77	5.37	7.25	9.14	10.88	13.05

Valve Sizing:

Please consult with Hydromine for clarification of correct sizing for your requirements.

Low Maintenance Requirement:

All the moving parts of LFC™ _3B Surge relief valve are manufactured from stainless steel which increases reliability and durability. The LFC™ _3B requires minimal maintenance, the majority of which, can be conducted with the valve remaining in situ.

Design & Manufacturing Standards:

The LFC™ _3B surge relief valve has been designed in accordance with various international standards as set out below:

ASME Boilers and pressure vessels design code

ANSI B16.10 ANSI B16.3

ANSI B16.34 ANSI B16.37

ANSI B16.5 ANSI N278 .1

Available sizes: DN50 / 2" to DN400 / 16"

Face to face dimensions to ANSI B16.10

Pressure rating: up to 2.5 MPa / 363 psi

Available end connections: ANSI B16.5, BS4504, BS10, AS/NZS 4331.1 (ISO 7005-1) DIN, all makes of grooved or ring joint couplings and other as per client's requirement.

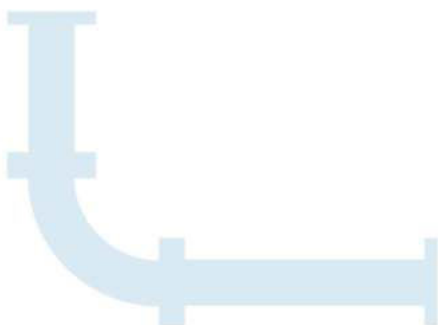



LFC™_3B Pressure Control Valve

Overview:

A pressure control valve is designed to maintain a desired downstream pressure irrespective of the flow requirement. The LFC™_3B pressure control valve is fitted with a modulating intelligent electrical actuator. Any make of electrical actuator can be fitted to the pressure control valve. The LFC™_3B pressure control valve has been developed to present a robust, simple and cost effective low pressure (up to 2.5 MPa / 363 Psi) solution to fluid handling issues in any industrial sector.

Features:

- Reduced cavitation
- Low noise levels
- Low vibration
- One moving part
- Long lasting

Low Maintenance Requirement:

All the moving parts of LFC™_3B pressure control valve are manufactured from stainless steel which increases reliability and durability. The LFC™_3B requires minimal maintenance, the majority of which, can be conducted with the valve remaining in situ.

Materials of Construction & Dimensions:

Part Name	Material Specification	Face To Face Dimensions		
		Valve size	Face to face #150	
		Unit	(mm)	(Inch)
Body	Casting - Ductile iron			
Body seat	431 / 304 S/ Steel			
Plug	431 / 304 S/ Steel	DN50 / 2"	203	7.99
V-Port	431 / 304 S/ Steel	DN80 / 3"	241	9.49
Spindle / Shaft	431 / 304 S/ Steel	DN100 / 4"	292	11.50
Plug seat	Polyurethane	DN150 / 6"	356	14.02
Sleeve	431 / 304 S/ Steel	DN200 / 8"	495	19.49
Sleeve Holder	Ductile iron	DN250 / 10"	622	24.49
O-Rings	Nitrile (Buna)	DN300 / 12"	699	27.52
Tripod rods	Carbon steel	DN350 / 14"	787	30.98
Bush holder	Ductile iron / Carbon steel	DN400 / 16"	914	35.98
Seals / O-Rings	Nitrile (Buna)			
Shaft seal	Polyurethane			
Wiper seal	Polyurethane			

Simplicity:

The LFC™_3B pressure control valve is designed to offer increased efficiency and accuracy as well as improve on ease of maintenance and in effect only has one moving part called the plug. The plug is a piston that is engineered to be balanced. The balanced plug enables easy opening and closing at any pressure and differential condition. The differential pressures do not affect the operating torque which results in a relatively flat torque curve allowing for the fitment of smaller actuators.

Robust, Reliable & Efficient

Due to the minimal number of moving parts to effect the fluid control, the number of potential failures are minimized.

Valve Sizing

Please consult with Hydromine for clarification of correct sizing for your requirements.

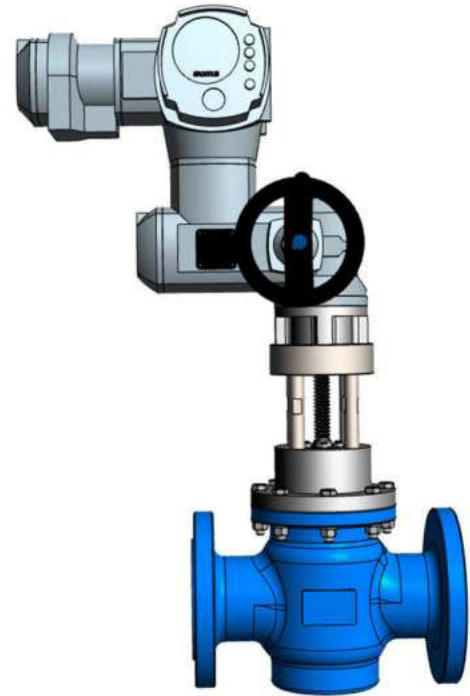



LFC™_3B Pressure Control Valve

Flow Rates:

Flow (ℓ/sec)	5	10	25	40	50	100	150	200	250	300	350	400
Pressure Drop (kPa)	DN50	47	94									
	DN80	17	34	86								
	DN100		23	57	79							
	DN150			26	36	51	102					
	DN200					28	56	84	112			
	DN250						37	55	73	91	112	
	DN300						26	37	50	63	75	90
Flow US gallon/ min	79.25	158.50	396.26	634.01	792.52	1585.03	2377.55	3170.06	3962.575	4755.09	5547.605	6340.12
Pressure Drop (psi)	2"	6.82	13.63									
	3"	2.47	4.93	12.47								
	4"		3.34	8.27	11.46							
	6"			3.77	5.22	7.4	14.79					
	8"					4.06	8.12	12.18	16.24			
	10"						5.37	7.98	10.59	13.2	16.24	
	12"						3.77	5.37	7.25	9.14	10.88	13.05

Plug Assembly, V-Port And Dealing With Cavitation:



As displayed, the LFC™_3B pressure control valve plug assembly and movements.

Closed Position: Shows the plug assembly on the body seat in a fully closed valve position.

5% Open Position: Shows the plug assemble in a 5% open position. It can clearly be seen that only the top of the V-Port opens up and creates a flow path. This reduces cavitation and helps with fine control at low flow conditions.

12% Open Position: Shows the plug assembly in the 12% open position. Now it can be observed how the V-Port moved away from the seat and the openings are increasing proportionally. At this point the top of the V-Ports are now being exposed to the flow path.

30% Open Position: Shows the plug assembly in the 30% opened position. Now it can clearly be seen that the full V-Port is creating a larger orifice in the flow path. Up to this point, cavitation needs to be dealt with to increase the life expectancy of the valve. The V-port trim ensures that the seating elements are further apart from each other during low flow allowing the cavitation to take place on noncritical components of the valve.

40% Open Position: Shows the plug assembly in the 40% open position. Now it can clearly be seen that the V-Port is completely away from the seat and the flow path is now relatively large. At this point the flow is approaching its medium demand flow rate and the V-Port has little to no function.

Design & Manufacturing Standards:

The LFC™_3B pressure control valve has been designed in accordance with various international standards as set out below:

ASME Boilers and pressure vessels design code

ANSI B16.10 ANSI B16.3
ANSI B16.34 ANSI B16.37
ANSI B16.5 ANSI N278.1

Available sizes: DN50 / 2" to DN400 / 16"
Face to face dimensions to ANSI B16.10
Pressure rating: up to 2.5 MPa / 363psi

Available end connections: ANSI B16.5, BS4504, BS10, AS/NZS 4331.1 (ISO 7005-1) DIN, all makes of grooved or ring joint couplings and other as per client's requirement.



LFC™ _3B Water Hydraulic Actuated Isolation Valves

Overview:

The LFC™ _3B Water hydraulic actuated isolation valves is based on the same design as the LFC™ _3B pressure regulating valve. Water hydraulic actuated valves are more cost effective than the LFC™ _3B electrical actuated valves. The upstream water hydraulic power are used to actuate the LFC™ _3B isolation valve. The speed of the valve can be adjusted to any desired speed fairly quickly and easily. The LFC™ _3B Water hydraulic actuated isolation valve are generally used for remote isolation, level control or pump discharge control valves. Using line fluids removes the need for any gearboxes, electrical actuators or handwheels which makes them ideal for applications where tampering is a problem.

The LFC™ _3B water hydraulic actuated valve has been developed to present a robust, simple and cost-effective low pressure (up to 2.5 MPa / 363Psi) solution to fluid handling issues in any industrial sector.

Low Operating Torque:

The LFC™ _3B Water hydraulic isolation valves are hydrostatically un-balanced to enable easy opening and closing at any pressure and differential conditions. It does not require the use of a gearbox or a by-pass valve to balance pressure between the inlet and outlet.

Operating Conditions:

These valves are designed to operate in systems with relatively clean media like water or other liquids with a low percentage of suspended solids and chlorides. The valve's operating pH range is 2 - 14 pH.

Simplicity:

The LFC™ _3B Water hydraulic valve is designed to minimize wearing parts and in effect only has one moving part called the plug assembly. The plug assembly is a piston that is engineered to be unbalanced. The unbalanced plug uses the inline fluid pressure to remove the influence of differential pressure on operating torque. As such, the valve operating torque is the torque required to overcome the sum of the friction forces generated between the valve body, seals and the cylinder plus the weight of the plug (depending on the installation configuration). This torque requirement is not affected by inline pressure variants and therefore makes these valves extremely good for actuation applications as well as for isolation valves where manual operation is required. Removal of gearboxes reduces maintenance requirements and improves troubleshooting times. The valve uses a water hydraulic control panels or solenoid valve to operate and it are simple in comparison with an electrical actuator. The LFC™ _3B Water hydraulic valve can easily be fitted with limit switches to give open and closed indication.

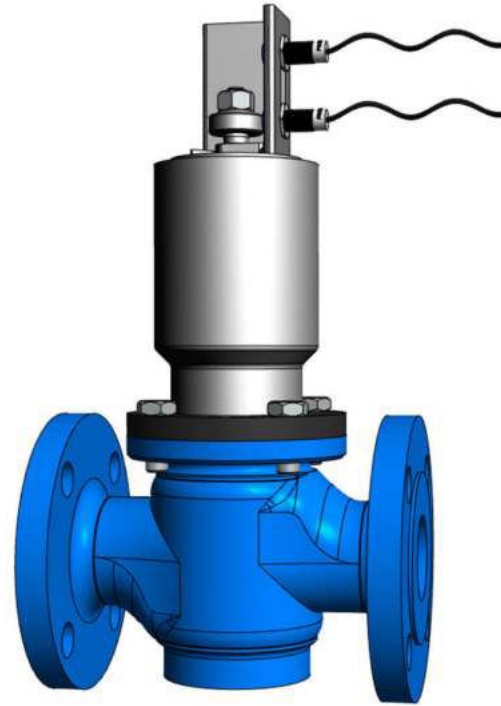

Materials of Construction & Dimensions:

Part Name	Material Specification	Face To Face Dimensions		
		Valve size	Face To face #150	
		Unit	(mm)	(Inch)
Body	Casting - Ductile iron			
Body seat	431 / 304 S/ Steel			
Plug	431 / 304 S/ Steel	DN50 / 2"	203	7.99
V-Port or Seat holder	431 / 304 S/ Steel	DN80 / 3"	241	9.49
Shaft	431 / 304 S/ Steel	DN100 / 4"	292	11.50
Piston	431 / 304 S/ Steel	DN150 / 6"	356	14.02
Plug seat	Polyurethane	DN200 / 8"	495	19.49
Sleeve	431 / 304 S/ Steel	DN250 / 10"	622	24.49
Sleeve Holder	Ductile iron	DN300 / 12"	699	27.52
Cylinder	431 / 304 S/ Steel	DN350 / 14"	787	30.98
Cylinder holder	Ductile iron	DN400 / 16"	914	35.98
Cylinder cover	Ductile iron			
Limit switch rod	431 / 304 S/ Steel			
Limit switch bracket	Carbon steel			
Limit switch bracket	Nitrile (Buna)			
Hoses	Single braided			



LFC™_3B Water Hydraulic Actuated Isolation Valves

Flow Rates:

Flow (ℓ/sec)	5	10	25	40	50	100	150	200	250	300	350	400
Pressure Drop (kPa)	DN50	47	94									
	DN80	17	34	86								
	DN100		23	57	79							
	DN150			26	36	51	102					
	DN200					28	56	84	112			
	DN250						37	55	73	91	112	
DN300						26	37	50	63	75	90	103
Flow US gallon/ min	79.25	158.50	396.26	634.01	792.52	1585.03	2377.55	3170.06	3962.575	4755.09	5547.605	6340.12
Pressure Drop (psi)	2"	6.82	13.63									
	3"	2.47	4.93	12.47								
	4"		3.34	8.27	11.46							
	6"			3.77	5.22	7.4	14.79					
	8"					4.06	8.12	12.18	16.24			
	10"						5.37	7.98	10.59	13.2	16.24	
	12"						3.77	5.37	7.25	9.14	10.88	13.05

Valve Sizing:

Please consult with Hydromine for clarification of correct sizing for your requirements.

LFC_3B Water Hydraulic Actuated Valve With Control Panel And Limit Switches:

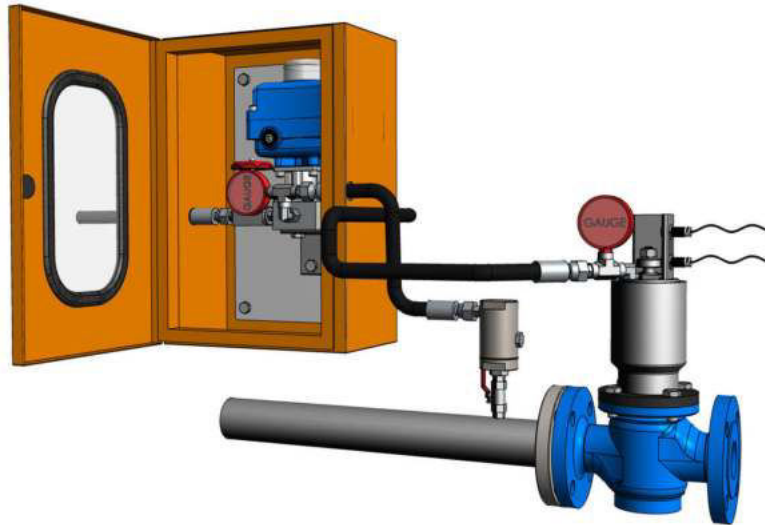

Low Maintenance Requirement:

All the moving parts of LFC™_3B water hydraulic actuated valve are manufactured from stainless steel which increases reliability and durability. The LFC™_3B requires minimal maintenance, the majority of which, can be conducted with the valve remaining in situ.

Design & Manufacturing Standards:

The LFC™_3B water hydraulic actuated valve has been designed in accordance with various international standards as set out below:

ASME Boilers and pressure vessels design code

ANSI B16.10 ANSI B16.3

ANSI B16.34 ANSI B16.37

ANSI B16.5 ANSI N278 .1

Available sizes: DN50 / 2" to DN400 / 16"

Face to face dimensions to ANSI B16.10

Pressure rating: up to 1.9 MPa / 275 psi

Available end connections: ANSI B16.5, BS4504, BS10, AS/NZS 4331.1 (ISO 7005-1) DIN, all makes of grooved or ring joint couplings and other as per client's requirement.



LFC™ _3B Level Control Valve

Overview:

The LFC™ _3B Level control valves are based on the same design as the LFC™ _3B pressure regulating valve. Using a float ball to actuate the LFC™ _3B level control valve is more cost effective than using electrical actuators to perform the same function. The upstream water hydraulic power is used to actuate the LFC™ _3B level control valve. The speed of the valve can be adjusted to any desired speed fairly quickly and easily. The LFC™ _3B Level control valve can be installed in remote locations where there is no access to electrical power. The LFC™ _3B Level control valve has been developed to present a robust, simple and cost-effective low pressure (up to 2.5 MPa / 363 Psi) solution to fluid handling issues in any industrial sector.

Low Maintenance Requirement:

All the moving parts of LFC™ _3B Level control valve are manufactured from stainless steel which increases reliability and durability. The LFC™ _3B requires minimal maintenance, the majority of which, can be conducted with the valve remaining in situ.



Materials of Construction & Dimensions:

Part Name	Material Specification	Valve size	Face To Face Dimensions	
			Unit	Face to face #150
			(mm)	(Inch)
Body	Casting - Ductile iron			
Body seat	431 / 304 S/ Steel			
Plug	431 / 304 S/ Steel	DN50 / 2"	203	7.99
V-Port or Seat holder	431 / 304 S/ Steel	DN80 / 3"	241	9.49
Shaft	431 / 304 S/ Steel	DN100 / 4"	292	11.50
Piston	431 / 304 S/ Steel	DN150 / 6"	356	14.02
Plug seat	Polyurethane	DN200 / 8"	495	19.49
Sleeve	431 / 304 S/ Steel	DN250 / 10"	622	24.49
Sleeve Holder	Ductile iron	DN300 / 12"	699	27.52
Cylinder	431 / 304 S/ Steel	DN350 / 14"	787	30.98
Cylinder holder	Ductile iron	DN400 / 16"	914	35.98
Cylinder cover	Ductile iron			
Hoses	Single braided			

Simplicity:

The LFC™ _3B Level control valve is designed to minimize wearing parts and in effect only has one moving part called the plug assembly. The plug assembly is a piston that is engineered to be un- balanced. The un- balanced plug uses the inline fluid pressure to remove the influence of differential pressure on operating torque. As such, the valve operating torque is the torque required to overcome the sum of the friction forces generated between the valve body, seals and the cylinder plus the weight of the plug (depending on the installation configuration). This torque requirement is not affected by inline pressure variants and therefore makes these valves extremely good for actuation applications as well as for isolation valves where manual operation is required. Removal of gearboxes reduces maintenance requirements and improves troubleshooting times. The valve uses a float ball valve to operate and it is simple in comparison with an electrical actuator. The LFC™ _3B Level control valve can easily be fitted with limit switches to give open and closed indication.

Low Operating Torque:

The LFC™ _3B Level control valves are hydrostatically un-balanced to enable easy opening and closing at any pressure and differential conditions. It does not require the use of a gearbox or by-pass valve to balance pressure between the inlet and outlet.

Valve Sizing

Please consult with Hydromine for clarification of correct sizing for your requirements.



LFC™_3B Level Control Valve

Flow Rates:

Flow (ℓ/sec)	5	10	25	40	50	100	150	200	250	300	350	400
Pressure Drop (kPa)	DN50	47	94									
	DN80	17	34	86								
	DN100		23	57	79							
	DN150			26	36	51	102					
	DN200					28	56	84	112			
	DN250						37	55	73	91	112	
	DN300						26	37	50	63	75	90
Flow US gallon/ min	79.25	158.50	396.26	634.01	792.52	1585.03	2377.55	3170.06	3962.575	4755.09	5547.605	6340.12
Pressure Drop (psi)	2"	6.82	13.63									
	3"	2.47	4.93	12.47								
	4"		3.34	8.27	11.46							
	6"			3.77	5.22	7.4	14.79					
	8"					4.06	8.12	12.18	16.24			
	10"						5.37	7.98	10.59	13.2	16.24	
	12"						3.77	5.37	7.25	9.14	10.88	13.05

Plug Assembly, V-Port And Dealing With Cavitation:



As displayed, the LFC™_3B level control valve plug assembly and movements.

Closed Position: Shows the plug assembly on the body seat in a fully closed valve position.

5% Open Position: Shows the plug assemble in a 5% open position. It can clearly be seen that only the top of the V-Port opens up and creates a flow path. This reduces cavitation and helps with fine control at low flow conditions.

12% Open Position: Shows the plug assembly in the 12% open position. Now it can be observed how the V-Port moved away from the seat and the openings are increasing proportionally. At this point the top of the V-Ports are now being exposed to the flow path.

30% Open Position: Shows the plug assembly in the 30% opened position. Now it can clearly be seen that the full V-Port is creating a larger orifice in the flow path. Up to this point, cavitation needs to be dealt with to increase the life expectancy of the valve. The V-port trim ensures that the seating elements are further apart from each other during low flow allowing the cavitation to take place on noncritical components of the valve.

40% Open Position: Shows the plug assembly in the 40% open position. Now it can clearly be seen that the V-Port is completely away from the seat and the flow path is now relatively large. At this point the flow is approaching its medium demand flow rate and the V-Port has little to no function.

Operating Conditions:

These valves are designed to operate in systems with relatively clean media like water or other liquids with a low percentage of suspended solids and chlorides. The valve's operating pH range is 2 - 14 pH.





LFC™_3B Level Control Valve

LFC™_3B Level Control Valve:

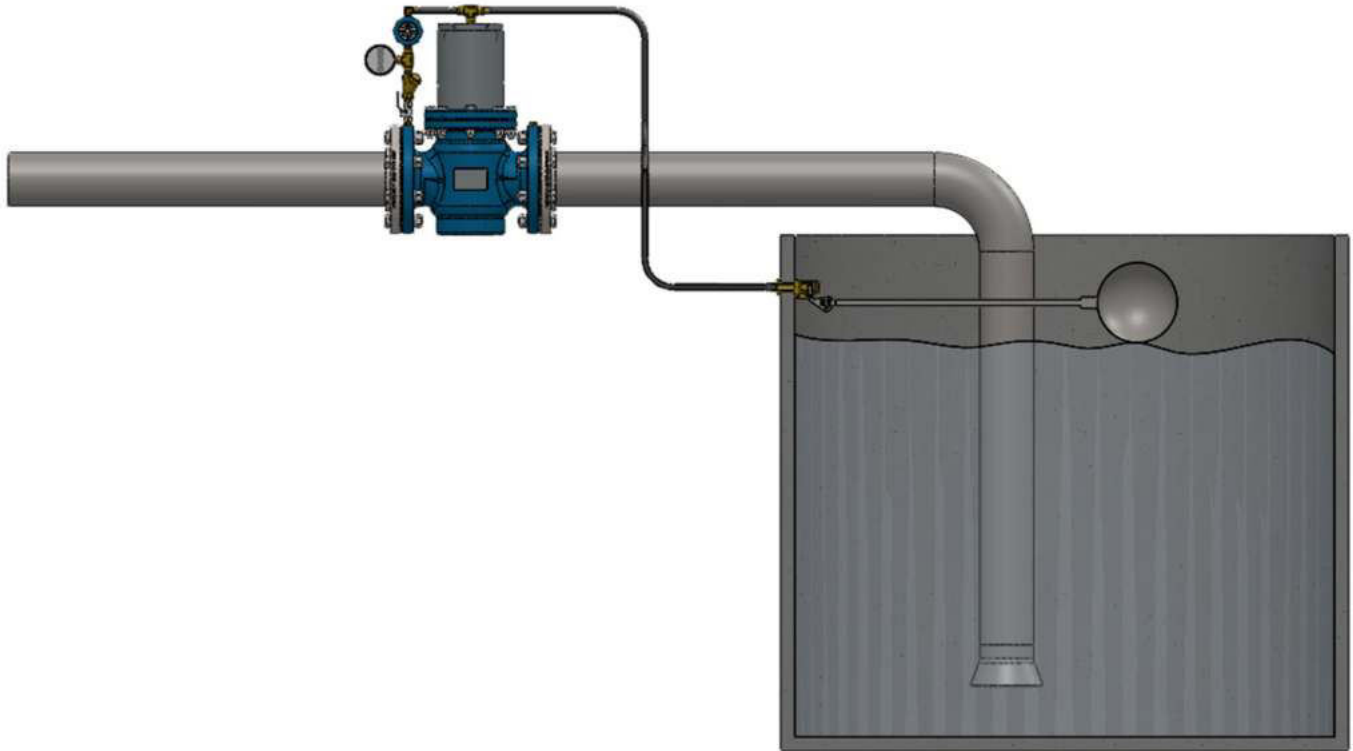

Design & Manufacturing Standards:

The LFC™_3B level control valve has been designed in accordance with various international standards as set out below:

ASME Boilers and pressure vessels design code

ANSI B16.10 ANSI B16.3
ANSI B16.34 ANSI B16.37
ANSI B16.5 ANSI N278.1

Available sizes: DN50 / 2" to DN400 / 16"

Face to face dimensions to ANSI B16.10

Pressure rating: up to 2.5 MPa / 363psi

Available end connections: ANSI B16.5, BS4504, BS10, AS/NZS 4331.1 (ISO 7005-1) DIN, all makes of grooved or ring joint couplings and other as per client's requirement.

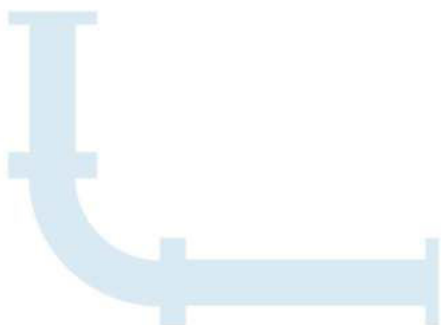



LFC™ _3B Pressure Regulating Valves

Overview:

A pressure regulating valve is designed to maintain a desired downstream pressure irrespective of the flow requirement. The LFC™ _3B fixed ratio pressure regulating valve has been developed to present a robust, simple and cost-effective low pressure (up to 2.5 MPa / 363 Psi) solution for fluid handling issues in any industrial sector.

Simplicity:

The LFC™ _3B pressure regulating valve is designed to minimize wearing parts and in effect has one moving part called the plug assembly. The plug assembly is a piston that is engineered to be unbalanced. The unbalanced plug assembly is designed to use inline fluid pressure to create specific conditions in the system without the use of an external controller or pilot.

A fixed reduction ratio can be established by fixing the surface area ratio exposed to the upstream and downstream pressures. Upstream pressure (P_u) would act to open the valve and downstream pressure (P_d) would act to close the valve. As the P_d increases, the closing force increases proportionally causing the valve to close. If P_d is reduced, the valve will open proportionally in an effort to maintain its hydraulic ratio.

Features:

- Reduced cavitation
- Low noise levels
- Low vibration
- One moving part
- Long lasting

Available Ratios
2:1
2.5:1
3:1
4:1
5:1

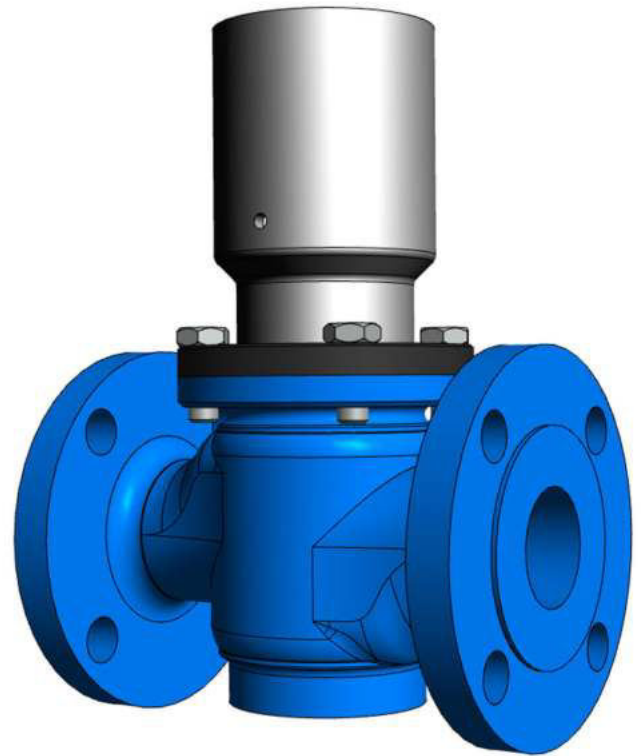

Materials Of Construction & Dimensions:

Part Name	Material Specification	Face To Face Dimensions		
		Valve size	Face to face #150	
		Unit	(mm)	(Inch)
Body	Casting - Ductile iron			
Body seat	431 / 304 S/ Steel			
Plug	431 / 304 S/ Steel	DN50 / 2"	203	7.99
V-Port	431 / 304 S/ Steel	DN80 / 3"	241	9.49
Piston rod	431 / 304 S/ Steel	DN100 / 4"	292	11.50
Piston	431 / 304 S/ Steel	DN150 / 6"	356	14.02
Plug seat	Polyurethane	DN200 / 8"	495	19.49
Sleeve	431 / 304 S/ Steel	DN250 / 10"	622	24.49
Sleeve Holder	Ductile iron	DN300 / 12"	699	27.52
Cylinder	431 / 304 S/ Steel	DN350 / 14"	787	30.98
Cylinder holder	Ductile iron	DN400 / 16"	914	35.98
Cylinder cover	Ductile iron			
O-Rings	Nitrile (Buna)			
Hose	Single braided			

Low Maintenance Requirement:

All the moving parts of LFC™ _3B pressure regulating valve are manufactured from stainless steel which increases reliability and durability. The LFC™ _3B requires minimal maintenance, the majority of which, can be conducted with the valve remaining in situ.





LFC™_3B Pressure Regulating Valves

Plug Assembly, V-Port And Dealing With Cavitation:

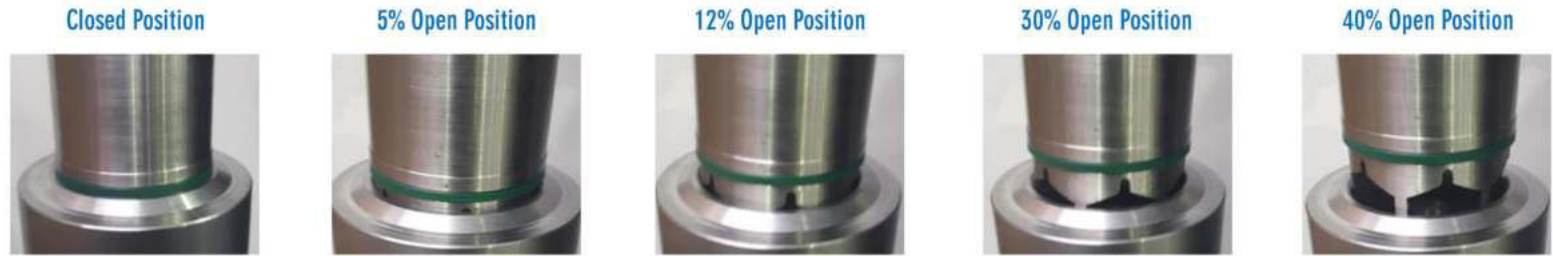

As displayed, the LFC™_3B pressure regulating valve plug assembly and movements.

Plug Assembly: 5% Open, showing the full plug assembly.

Closed Position: Shows the plug assembly on the body seat in a fully closed valve position.

5% Open Position: Shows the plug assembly in a 5% open position. It can clearly be seen that only the top of the V-Port opens up and creates a flow path. This reduces cavitation and helps with fine control at low flow conditions.

12% Open Position: Shows the plug assembly in the 12% open position. Now it can be observed how the V-Port moved away from the seat and the openings are increasing proportionally. At this point the top of the V-Ports are now being exposed to the flow path.

30% Open Position: Shows the plug assembly in the 30% opened position. Now it can clearly be seen that the full V-Port is creating a larger orifice in the flow path. Up to this point, cavitation needs to be dealt with to increase the life expectancy of the valve. The V-port trim ensures that the seating elements are further apart from each other during low flow allowing the cavitation to take place on non critical components of the valve.

40% Open Position: Shows the plug assembly in the 40% open position. Now it can clearly be seen that the V-Port is completely away from the seat and the flow path is now relatively large. At this point the flow is approaching its medium demand flow rate and the V-Port has little to no function.

Flow Rates:

Flow (l/sec)		5	10	25	40	50	100	150	200	250	300	350	400
Pressure Drop (kPa)	DN50	47	94										
	DN80	17	34	86									
	DN100		23	57	79								
	DN150			26	36	51	102						
	DN200					28	56	84	112				
	DN250						37	55	73	91	112		
	DN300						26	37	50	63	75	90	103
Flow US gallon/ min		79.25	158.50	396.26	634.01	792.52	1585.03	2377.55	3170.06	3962.575	4755.09	5547.605	6340.12
Pressure Drop (psi)	2"	6.82	13.63										
	3"	2.47	4.93	12.47									
	4"		3.34	8.27	11.46								
	6"			3.77	5.22	7.4	14.79						
	8"					4.06	8.12	12.18	16.24				
	10"						5.37	7.98	10.59	13.2	16.24		
	12"						3.77	5.37	7.25	9.14	10.88	13.05	14.96

Valve Sizing:

Please consult with Hydromine for clarification of correct sizing for your requirements.





LFC™_3B Pressure Regulating Valves

Robust, Reliable And Efficient:

Due to the minimal number of moving parts to effect the fluid control, the number of potential failures are minimized. The valve can only fail for the following reasons:

1. **Lack of maintenance:** If filters are utilized in the control system, regular cleaning of the filters are required to prevent the valve operation from slowing down and eventually creating a possible hydraulic locking of the valve. This process depends on the condition of the service water being used. The dirtier the water, the shorter the filter maintenance intervals will need to be. A valve seal replacement program should be employed to ensure that the valves shuttle seals are replaced in accordance with manufacturer's recommendations. As these seals are largely protected the intervals for maintenance on these items can usually be done in terms of years. If these seals fail, the valve will start to bypass pressure from the Pu to the control chamber on the unbalanced valves. Pressure regulating valves are equipped with tell-tale breather holes in the side of the cylinder which will immediately indicate seal failure.
2. **Mechanical fouling:** Should a large object be introduced into the service water piping and reach the valve inlet, such object could create a mechanical jam and prevent the shuttle from operating.
3. **Overriding of the control system:** As the valve is hydraulically actuated and controlled, if the control system is isolated from the service water by way of isolation valves in the control system, the valve will be hydraulically locked in position and will be unable to adjust to the inline condition changes.
4. **Mechanical failure of the main seating arrangement:** In time, the seating arrangement will experience conditions of high velocity across the seating surface during low flow conditions. The high velocity will eventually cause wear on the seating surface and on the plug seating surface. If the valves starts to bypass across its seat, the downstream pressure could increase to the point where the surge relief valve is activated during low flow conditions.

All of these conditions are easily avoidable and rectifiable through regular maintenance programs and service water quality control and condition monitoring.

Design & Manufacturing Standards:

The LFC™_3B pressure regulating valve has been designed in accordance with various international standards as set out below:

ASME Boilers and pressure vessels design code

ANSI B16.10 ANSI B16.3

ANSI B16.34 ANSI B16.37

ANSI B16.5 ANSI N278 .1

Available sizes: DN50 / 2" to DN400 / 16"

Face to face dimensions to ANSI B16.10

Pressure rating: up to 2.5 MPa / 363 psi

Available end connections: ANSI BI 6.5, BS4504, BS10, AS/NZS 4331.1 (ISO 7005-1) DIN, all makes of grooved or ring joint couplings, and other as per clients requirement.

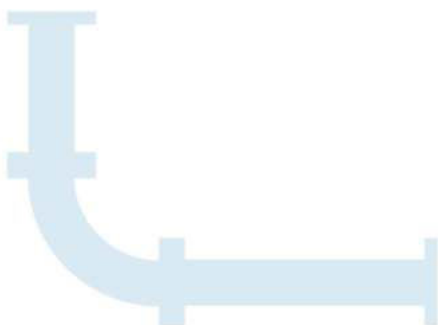



LFC™_3B Pilot Operated Pressure Regulating Valve

Overview:

A pressure regulating valve is designed to maintain a desired downstream pressure irrespective of the flow requirement. The LFC™_3B variable ratio pressure regulating valve has been developed to present a robust, simple and cost-effective low pressure (up to 2.5 MPa / 363 psi) solution to fluid handling issues in any industrial sector.

Features:

- Reduced cavitation
- Low noise levels
- Low vibration
- One moving part
- Long lasting

Simplicity:

The LFC™_3B Pilot operated pressure regulating valve is designed to minimize wearing parts and in effect only has one moving part called the plug assembly. The plug assembly is a piston that is engineered to be unbalanced. The unbalanced plug assembly combined with a pilot are designed to use inline fluid pressure to create specific conditions in the system.

Its equipped with a 3-way pilot that controls the downstream pressure. A needle valve allows upstream pressure to flow into the valve top closing compartment at a controlled flow rate.

The pilot releases pressure from the valve to compartment at an adjustable rate. By adjusting the adjustment screw, the downstream control pressure can be adjusted to the desired downstream pressure. The pilot will ensure that the downstream pressure will remain stable, even if the upstream pressure changes with demand changes.

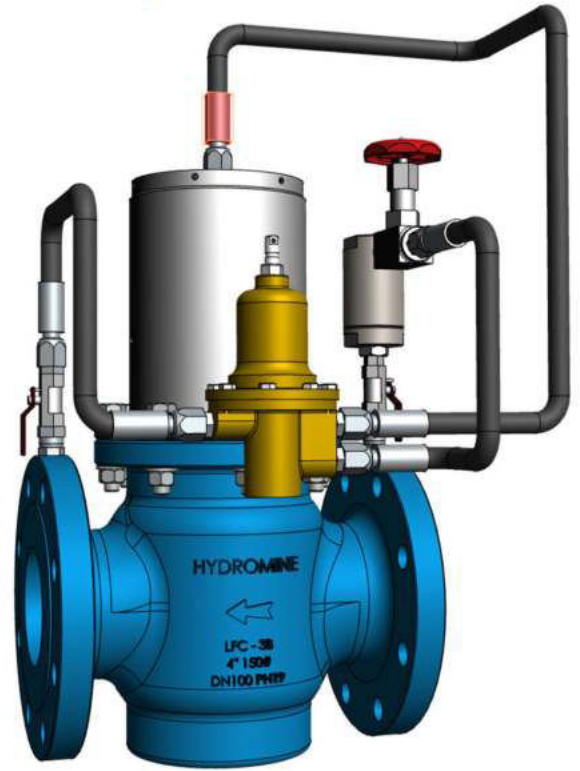

Materials of Construction & Dimensions:

Part Name	Material Specification	Valve size	Face To Face Dimensions	
			Unit	Face to face #150
			(mm)	(Inch)
Body	Coating - Ductile iron			
Body seat	431 / 304 S/ Steel			
Plug	431 / 304 S/ Steel	DN50 / 2"	203	7.99
V-Port	431 / 304 S/ Steel	DN80 / 3"	241	9.49
Piston rod	431 / 304 S/ Steel	DN100 / 4"	292	11.50
Piston	431 / 304 S/ Steel	DN150 / 6"	356	14.02
Plug seat	Polyurethane	DN200 / 8"	495	19.49
Sleeve	431 / 304 S/ Steel	DN250 / 10"	622	24.49
Sleeve Holder	Ductile iron	DN300 / 12"	699	27.52
Cylinder	431 / 304 S/ Steel	DN350 / 14"	787	30.98
Cylinder holder	Ductile iron	DN400 / 16"	914	35.98
Cylinder cover	Ductile iron			
O-Rings	Nitrile (Buna)			
Hoses	Single braided			

Low Maintenance Requirement:

All the moving parts of LFC™_3B surge relief valve are manufactured from stainless steel which increases reliability and durability. The LFC™_3B requires minimal maintenance, the majority of which, can be conducted with the valve remaining in situ.





LFC™_3B Pilot Operated Pressure Regulating Valve

Plug Assembly, V-Port And Dealing With Cavitation:

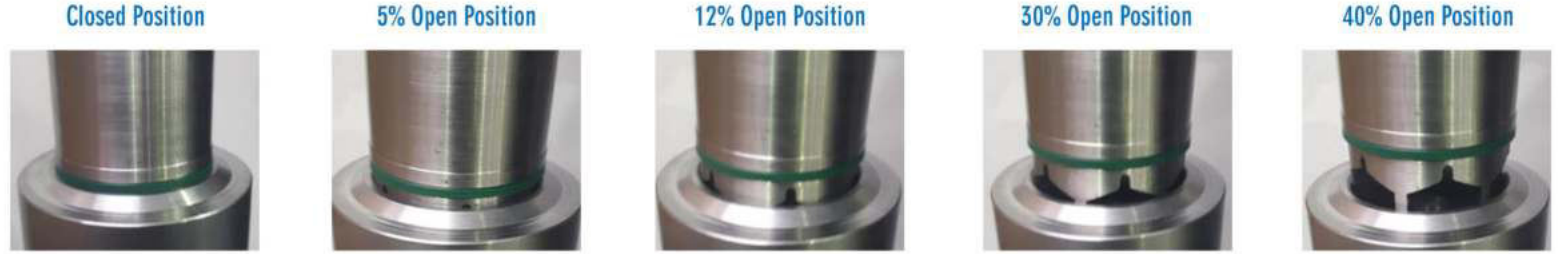

As displayed, the LFC™_3B pressure regulating valve plug assembly and movements.

Closed Position: Shows the plug assembly on the body seat in a fully closed valve position.

5% Open Position: Shows the plug assembly in a 5% open position. It can clearly be seen that only the top of the V-Port opens up and creates a flow path. This reduces cavitation and helps with fine control at low flow conditions.

12% Open Position: Shows the plug assembly in the 12% open position. Now it can be observed how the V-Port moved away from the seat and the openings are increasing proportionally. At this point the top of the V-Ports are now being exposed to the flow path.

30% Open Position: Shows the plug assembly in the 30% opened position. Now it can clearly be seen that the full V-Port is creating a larger orifice in the flow path. Up to this point, cavitation needs to be dealt with to increase the life expectancy of the valve. The V-port trim ensures that the seating elements are further apart from each other during low flow allowing the cavitation to take place on noncritical components of the valve.

40% Open Position: Shows the plug assembly in the 40% open position. Now it can clearly be seen that the V-Port is completely away from the seat and the flow path is now relatively large. At this point the flow is approaching its medium demand flow rate and the V-Port has little to no function.

Flow Rates:

Flow (l/sec)	5	10	25	40	50	100	150	200	250	300	350	400
Pressure Drop (kPa)	DN50	47	94									
	DN80	17	34	86								
	DN100		23	57	79							
	DN150			26	36	51	102					
	DN200					28	56	84	112			
	DN250						37	55	73	91	112	
	DN300						26	37	50	63	75	90
Flow US gallon/ min	79.25	158.50	396.26	634.01	792.52	1585.03	2377.55	3170.06	3962.575	4755.09	5547.605	6340.12
Pressure Drop (psi)	2"	6.82	13.63									
	3"	2.47	4.93	12.47								
	4"		3.34	8.27	11.46							
	6"			3.77	5.22	7.4	14.79					
	8"					4.06	8.12	12.18	16.24			
	10"						5.37	7.98	10.59	13.2	16.24	
	12"						3.77	5.37	7.25	9.14	10.88	13.05

Robust, Reliable And Efficient:

Due to the minimal number of moving parts to affect the fluid control, the number of potential failures is minimized. The valve can only fail for the following reasons:

1. **Lack of maintenance:** If filters are utilized in the control system, regular cleaning of the filters are required to prevent the valve operation from slowing down and eventually creating a possible hydraulic locking of the valve. This process depends on the condition of the service water being used. The dirtier the water, the shorter the filter maintenance intervals will need to be. A valve seal replacement program should be employed to ensure that the valves plug seals are replaced in accordance with manufacturer's recommendations. As these seals are largely protected the intervals for maintenance on these items can usually be done in terms of years. If these seals fail, the valve will start to bypass pressure from the Pu to the control chamber on the unbalanced valves. Balanced valves are equipped with tell-tale breather holes in the cylinder holder which will immediately indicate seal failure.

2. **Mechanical fouling:** Should a large object be introduced into the service water piping and reach the valve inlet; such object could create a mechanical jam and prevent the plug assembly from operating.



LFC™ _3B Pilot Operated Pressure Regulating Valve

Robust, Reliable And Efficient Cont.:

3. Overriding of the control system: As the valve is hydraulically actuated and controlled, if the control system is isolated from the service water by way of isolation valves in the control system, the valve will be hydraulically locked in position and will be unable to adjust to the inline condition changes.

4. Mechanical failure of the main seating arrangement: In time, the seating arrangement will experience conditions of high velocity across the seating surface during low flow conditions. The high velocity will eventually cause wear on the seating surface and on the plug seating surface. If the valves start to bypass across its seat, the down stream pressure could increase to the point where the pressure relief valve is activated during low flow conditions.

All of these conditions are easily avoidable and rectifiable through regular maintenance programs and service water quality control and condition monitoring.

Design & Manufacturing Standards:

The LFC™ _3B has been designed in accordance with various international standards as set out below: ASME Boilers and pressure vessels design code

ANSI B16.10 ANSI B16.3
ANSI B16.34 ANSI B16.37
ANSI B16.5 ANSI N278.1

Available sizes: DN50 / 2" to DN400 / 16"
Face to face dimensions to ANSI B16.10
Pressure rating: up to 2,5 MPa / 363 psi

Available end connections: ANSI B1 6.5, BS4504, BS10, AS/NZS 4331.1 (ISO 7005-1) DIN, all makes of grooved or ring joint couplings, and other as per client's requirement.

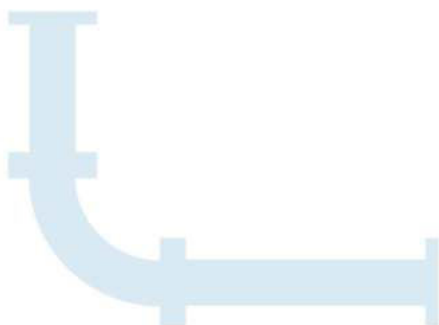



LFC™ _3B Electrically Actuated Isolation Valve

Overview:

The LFC™ _3B Electrically actuated Isolating valves were designed to be simple and easy to operate.

Due to the hydraulically balanced design and low torque requirements the valve requires a relatively small electrical actuator with no external gearbox. This feature saves capital and long term maintenance costs. Any make of electrical actuator can be fitted on the LFC™ _3B electrically actuated isolation valve. The LFC™ _3B electrically actuated isolation valves are generally used in pump discharge control, PLC regulated control or any other automated applications. The LFC™ _3B electrically actuated isolation valve has been developed to present a robust, simple and cost effective low pressure (up to 2.5 MPa / 363 Psi) solution to fluid handling issues in any industrial sector.

Low Operating Torque:

The LFC™ _3B Electrically isolation valve is hydrostatically balanced to enable easy opening and closing at any pressure and differential conditions. It does not require the use of a gearbox or a by-pass valve to balance pressure between the inlet and outlet. The differential pressures do not affect the operating torque which results in a relatively flat torque curve allowing for the fitment of smaller actuators.

Operating Conditions:

These valves are designed to operate in systems with relatively clean media like water or other liquids with a low percentage of suspended solids and chlorides. The valve's operating pH range is 2 - 14 pH.

Simplicity:

The LFC™ _3B valve is designed to minimize wearing parts and in effect only has one moving part called the plug. The plug is a piston that is engineered to be balanced. The balanced plug uses the inline fluid pressure to remove the influence of differential pressure on operating torque. As such, the valve operating torque is the torque required to overcome the sum of the friction forces generated between the valve seals and the sleeve plus the weight of the plug (depending on the installation configuration). This torque requirement is not affected by inline pressure variants and as such makes the balanced valves extremely good for actuation applications. Removal of gearboxes reduces maintenance requirements and improves troubleshooting times.

Low Maintenance Requirement:

All the moving parts of the LFC™ _3B Electrically isolation valves are manufactured from stainless steel which increases reliability and durability. The LFC™ _3B requires minimal maintenance, the majority of which, can be conducted with the valve remaining in situ.

Robust, Reliable & Efficient:

Due to the minimal number of moving parts to effect the fluid control, the number of potential failures are minimized.

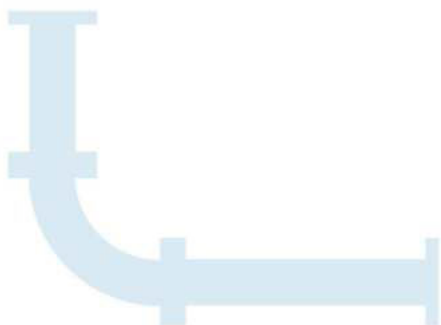



LFC™ _3B Electrically Actuated Isolation Valve

Flow Rates:

Flow (ℓ/sec)	5	10	25	40	50	100	150	200	250	300	350	400
Pressure Drop (kPa)	DN50	47	94									
	DN80	17	34	86								
	DN100		23	57	79							
	DN150			26	36	51	102					
	DN200					28	56	84	112			
	DN250						37	55	73	91	112	
	DN300						26	37	50	63	75	90
Flow US gallon/ min	79.25	158.50	396.26	634.01	792.52	1585.03	2377.55	3170.06	3962.575	4755.09	5547.605	6340.12
Pressure Drop (psi)	2"	6.82	13.63									
	3"	2.47	4.93	12.47								
	4"		3.34	8.27	11.46							
	6"			3.77	5.22	7.4	14.79					
	8"					4.06	8.12	12.18	16.24			
	10"						5.37	7.98	10.59	13.2	16.24	
	12"						3.77	5.37	7.25	9.14	10.88	13.05

Valve Sizing:

Please consult with Hydromine for clarification of correct sizing for your requirements.

Materials Of Construction & Dimensions:

Part Name	Material Specification	Face To Face Dimensions		
		Valve size Unit	(mm)	(Inch)
Body	Casting - Ductile iron		Face to face #150	
Body seat	431 / 304 S/ Steel			
Plug	431 / 304 S/ Steel	DN50 / 2"	203	7.99
V-Port	431 / 304 S/ Steel	DN80 / 3"	241	9.49
Spindle / Shaft	431 / 304 S/ Steel	DN100 / 4"	292	11.50
Plug seat	Polyurethane	DN150 / 6"	356	14.02
Sleeve	431 / 304 S/ Steel	DN200 / 8"	495	19.49
Sleeve Holder	Ductile iron	DN250 / 10"	622	24.49
O-Rings	Nitrile (Buna)	DN300 / 12"	699	27.52
Tripod rods	Carbon steel	DN350 / 14"	787	30.98
Bush holder	Ductile iron / Carbon steel	DN400 / 16"	914	35.98
Seals / O-Rings	Nitrile (Buna)			
Shaft seal	Polyurethane			
Wiper seal	Polyurethane			

Design & Manufacturing Standards:

The LFC™ _3B electrically actuated isolation valve has been designed in accordance with various international standards as set out below:

ASME Boilers and pressure vessels design code

ANSI B16.10 ANSI B16.3

ANSI B16.34 ANSI B16.37

ANSI B16.5 ANSI N278.1

Available sizes: DN50 / 2" to DN400 / 16"

Face to face dimensions to ANSI B16.10

Pressure rating: up to 2.5 MPa / 363psi

Available end connections: ANSI B16.5, BS4504, BS10, AS/NZS 4331.1 (ISO 7005-1) DIN, all makes of grooved or ring joint couplings and other as per client's requirement.





LFC™ _3B Surge Prevention Valve

Overview:

The LFC™ _3B Surge prevention system is designed to prevent water hammer or pressure surges in pumping systems. Especially in mining applications. Water hammer (or, more generally, fluid hammer) is a pressure surge or wave resulting when a fluid in motion is forced to stop or change direction suddenly (Momentum Change).

Water hammer commonly occurs when a pump is stopped suddenly and a pressure wave propagates in the pipe. It is a force that can arise in any pumping system that undergoes abrupt changes in its rate of flow. These flow changes can result from pump starts and stops, the opening and closing of valves, and water column separation and closure. The piping design does have an effect upon water hammer but, we have identified the main conditions resulting in hammer.

When Does Water Hammer / Pressure Surge Occur?

Water hammer will normally occur in a pumping system when one of 3 conditions occur:

1. A total power failure, causing all the running pumps to trip.
2. The emergency stop is activated on the last running pump.
3. Tripping of the last running pump.

Water Hammer / Pressure Surge:

Typically water hammer travels at the speed of sound through its medium which can amount to 1 481 m/s (Ave 995m/s) in water. Water is only partially compressible. At ambient temperature one pound of pressure will decrease its volume by a factor of about 0.0000034. The larger the volume of water, the easier it is to see the effect of water hammer. Compression begins at the leading edge of the water column and when the additional energy it produces cannot continue on past the closed valve (Non Return valves), a pressure or shock wave is generated which travels back upstream. The inception of this shock wave is very similar to the "echo" that is produced when a sound wave, traveling through air, strikes some barrier. When the wave hits the upstream valve it is reflected back downstream but with a diminished intensity. This, back and forth, motion continues until friction and reflection losses cause the waves to dissipate. The speed at which a wave travels and the energy it loses during travel depends upon the density and compressibility of the medium in which it is traveling. It turns out that the density and compressibility of water make it a very good medium for shock wave generation and transmission.

Simplicity:

The LFC™ _3B Surge prevention valve system is designed to minimize wearing parts and in effect only has one moving part called the plug assembly. The plug assembly is a piston that is engineered to be un-balanced. The LFC™ _3B Surge prevention valve is water hydraulically actuated using an hydraulic switch. The function of the hydraulic switch is to displace water from the control chamber of the valve rapidly.

This rapid displacement of water causes the surge prevention valve to open extremely quickly. The hydraulic switch is controlled using a compact oil hydraulic power pack.

Low Maintenance Requirement:

All the moving parts of the LFC™ _3B Surge Prevention valves are manufactured from stainless steel which increases reliability and durability. The LFC™ _3B valve range requires minimal maintenance, the majority of which, can be conducted with the valve remaining in situ.

Operating Conditions:

These valves are designed to operate in systems with relatively clean media like water or other liquids with a low percentage of suspended solids and chlorides. The valve's operating pH range is 2 - 14 pH.

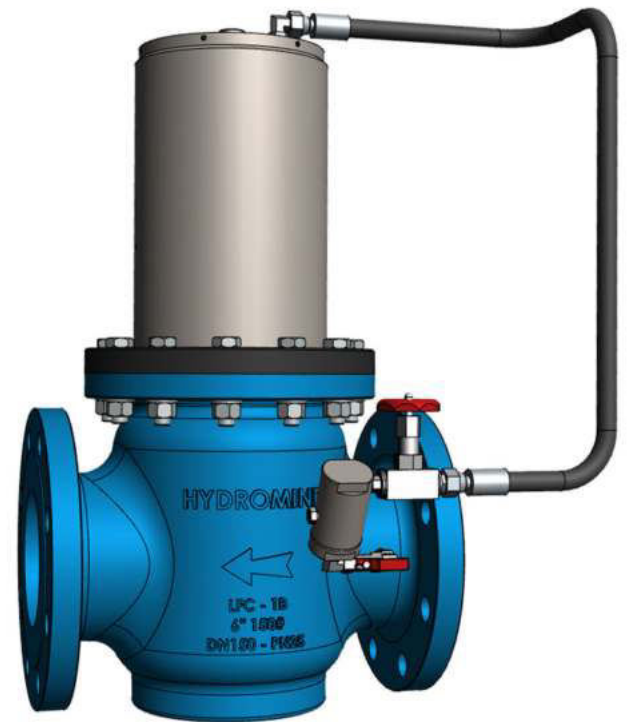



LFC™_3B Surge Prevention Valve

The Effects Of Water Hammer / Pressure Surge:

The graph shows the effects of water hammer on a pump station in an Mine, with an underground pump station of 770m static head when 1 pump tripped.

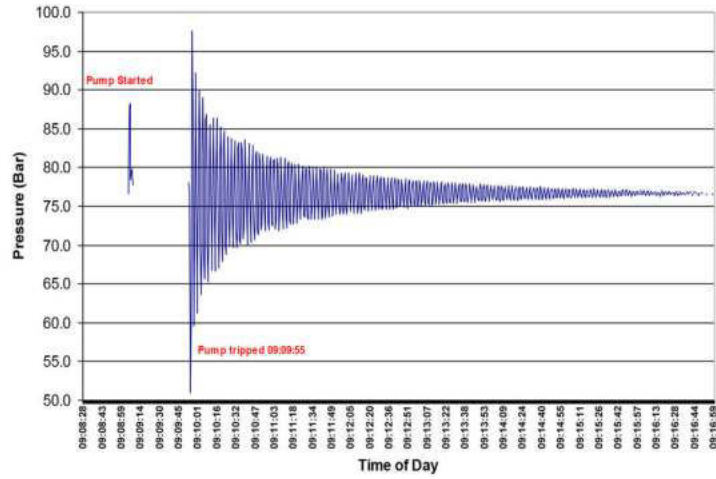

The graph shows the effects of water hammer in a Mine pump station, with an underground pump station of 786m static head when 2 pumps tripped.

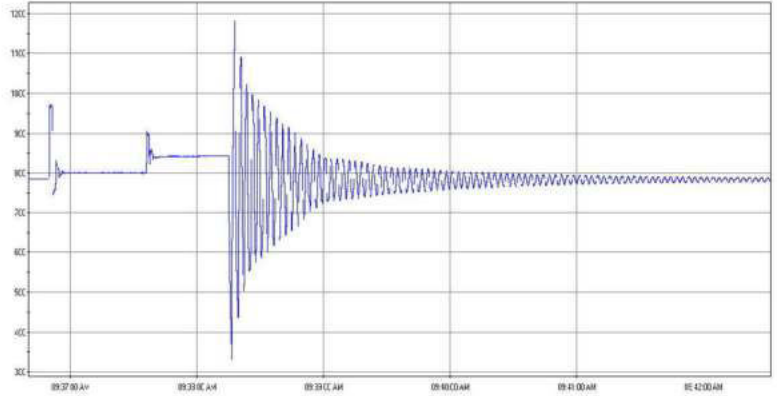

How Does It Work?

The LFC™_3B Surge prevention valve opens rapidly when there is an abrupt stop of the last running pump, or a total power failure during dewatering. At that stage the flow is still moving away from the pump station, but as soon as it loses its driving force and energy it will start returning towards the pump station. Due to the open LFC™_3B Surge prevention valve, the returning column of water is met with an open orifice and an exit point for any energy build up.

The flow moves through the surge prevention valve and energy dissipator installed after the valve. After keeping the LFC™_3B Surge prevention valve open for +/- 10 seconds, the surge prevention valve starts closing in a controlled manner to prevent any surging. The function of the energy dissipator is to discharge the flow at safe pressure and a set flow to atmosphere into the suction dam or drain.

The graph on the left shows the effects of water hammer on an underground pump station with 920m static head when 1 pump tripped. The graph on the right shows the result of using the LFC™_3B surge prevention valve system in the same pump station, when 1 pump tripped. It clearly demonstrates the effectiveness of the solution and shows that no water hammer was experienced.

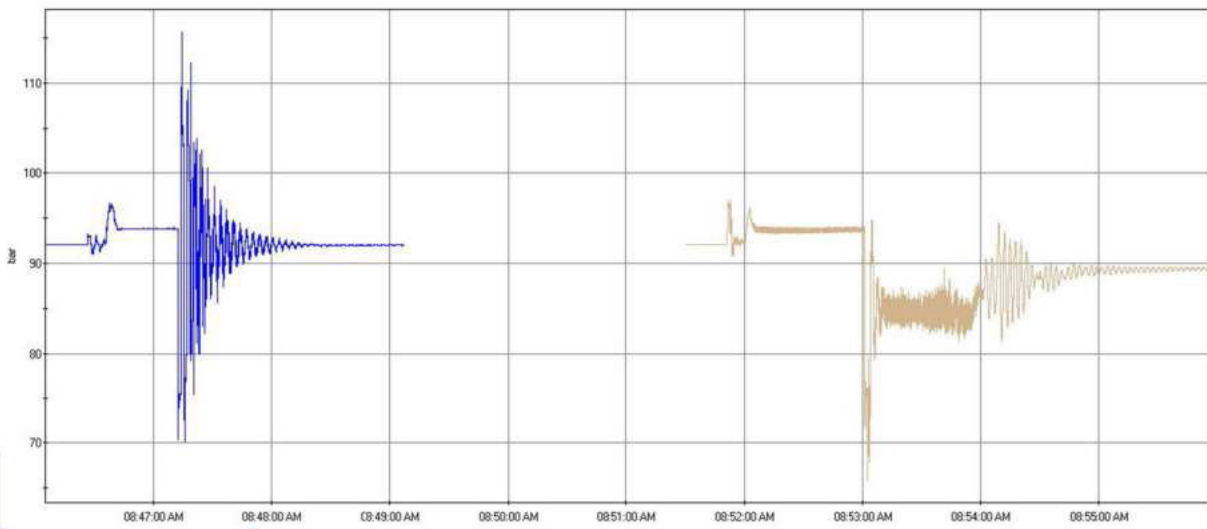
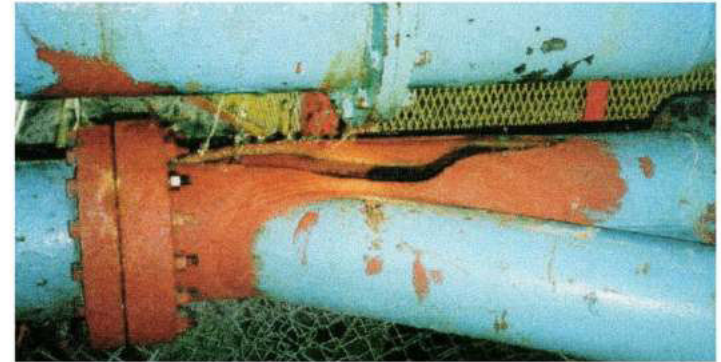



LFC™ _3B Surge Prevention Valve

LFC Surge Prevention System With Compact Oil Hydraulic Power Pack:

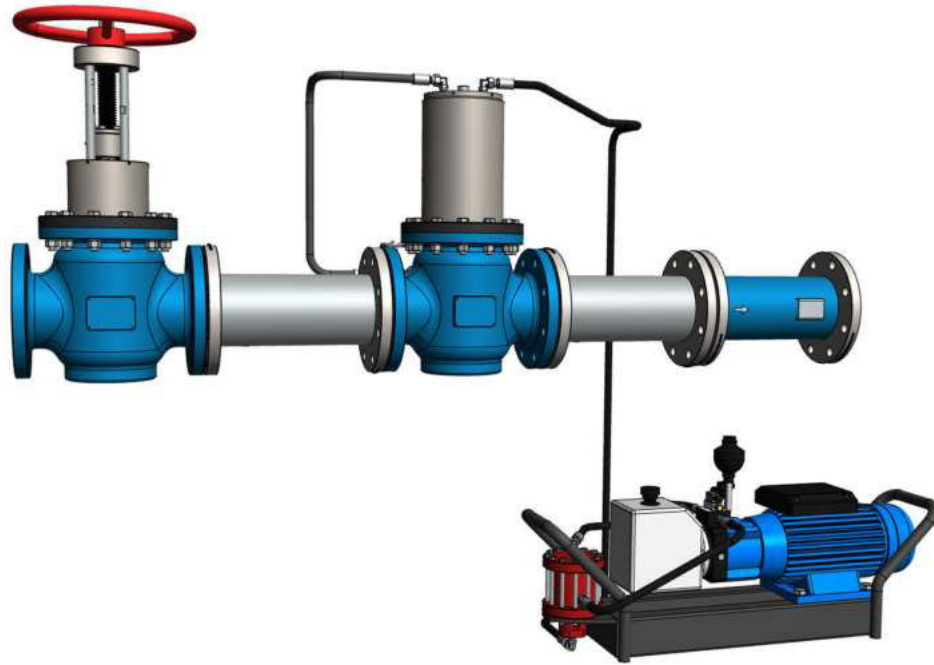

Materials Of Construction & Dimensions:

Part Name	Material Specification	Face To Face Dimensions		
		Valve size Unit	Face to face #150 (mm)	(Inch)
Body	Coating - Ductile iron			
Body seat	431 / 304 S/ Steel			
Plug	431 / 304 S/ Steel	DN50 / 2"	203	7.99
Seat retaining ring	431 / 304 S/ Steel	DN80 / 3"	241	9.49
Piston rod	431 / 304 S/ Steel	DN100 / 4"	292	11.50
Piston	431 / 304 S/ Steel	DN150 / 6"	356	14.02
Plug seat	Polyurethane	DN200 / 8"	495	19.49
Sleeve	431 / 304 S/ Steel	DN250 / 10"	622	24.49
Sleeve Holder	Ductile iron	DN300 / 12"	699	27.52
Cylinder	431 / 304 S/ Steel	DN350 / 14"	787	30.98
Cylinder holder	Ductile iron	DN400 / 16"	914	35.98
Cylinder cover	Ductile iron			
O-Rings	Nitrile (Buna)			
Hoses	Single braided			

Flow Rates:

Flow (l/sec)	5	10	25	40	50	100	150	200	250	300	350	400
Pressure Drop (kPa)	DN50	47	94									
	DN80	17	34	86								
	DN100		23	57	79							
	DN150			26	36	51	102					
	DN200					28	56	84	112			
	DN250						37	55	73	91	112	
	DN300						26	37	50	63	75	90
Flow US gallon/ min	79.25	158.50	396.26	634.01	792.52	1585.03	2377.55	3170.06	3962.575	4755.09	5547.605	6340.12
Pressure Drop (psi)	2"	6.82	13.63									
	3"	2.47	4.93	12.47								
	4"		3.34	8.27	11.46							
	6"			3.77	5.22	7.4	14.79					
	8"					4.06	8.12	12.18	16.24			
	10"						5.37	7.98	10.59	13.2	16.24	
	12"						3.77	5.37	7.25	9.14	10.88	13.05



LFC™ _3B Surge Prevention Valve

Surge Prevention System:

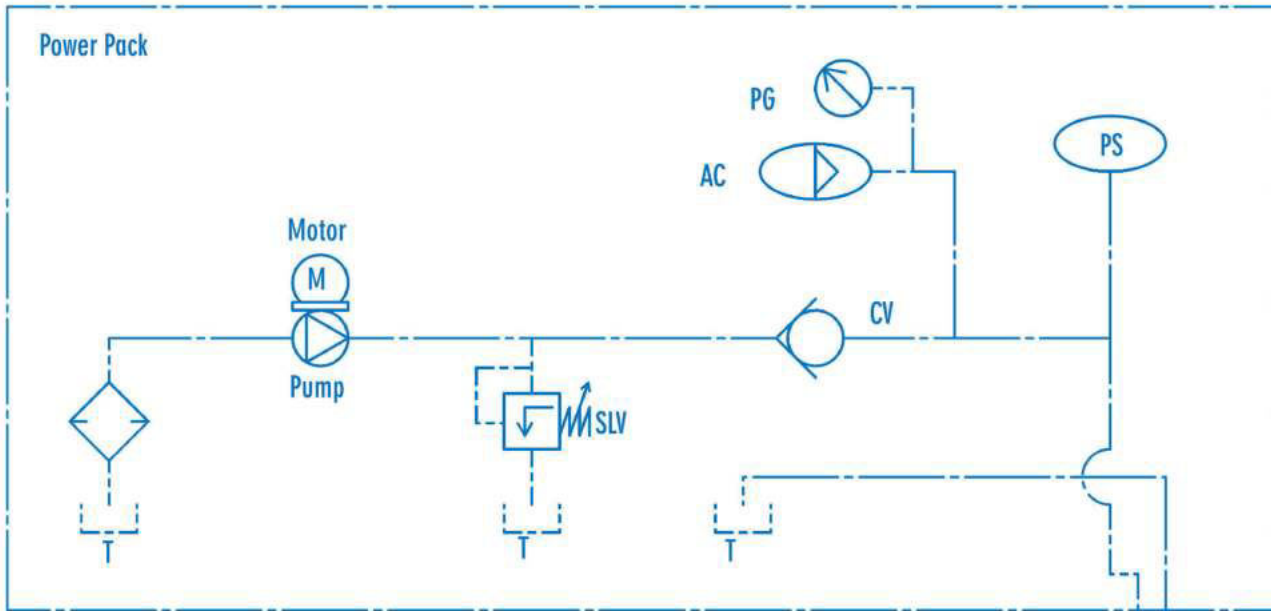

Key:

- BV – Ball Valve
- STR – STR
- NV – Needle Valve
- SV – Solenoid Valve
- AC – Accumulator
- SLV – Oil Pressure Relief Valve
- PG – Pressure Gauge
- T – Tank
- CV – Check Valve
- N/C HS – Nominally Closed Hydraulic Switch
- PS - Pressure switch

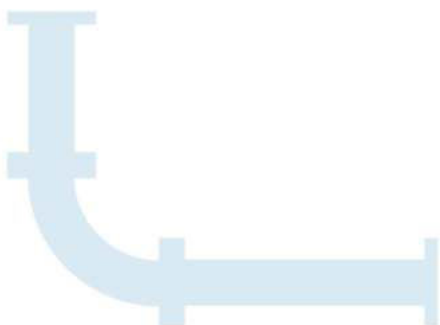
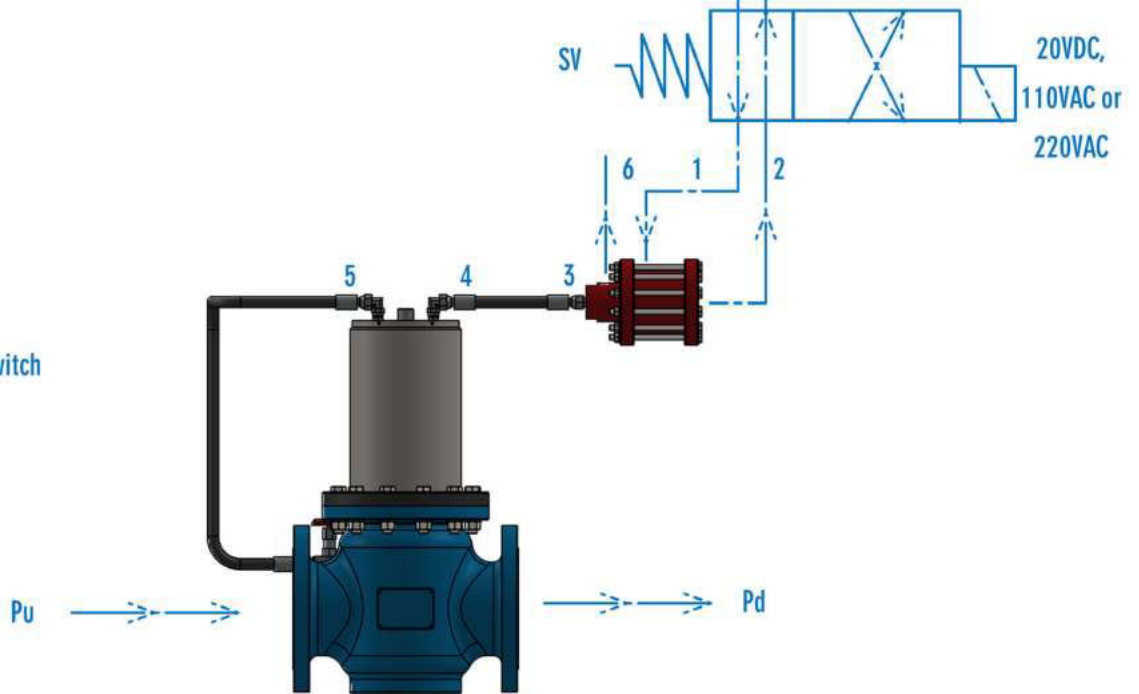



LFC™_3B Surge Prevention Valve

Typical Pump Station With Surge Prevention System.:

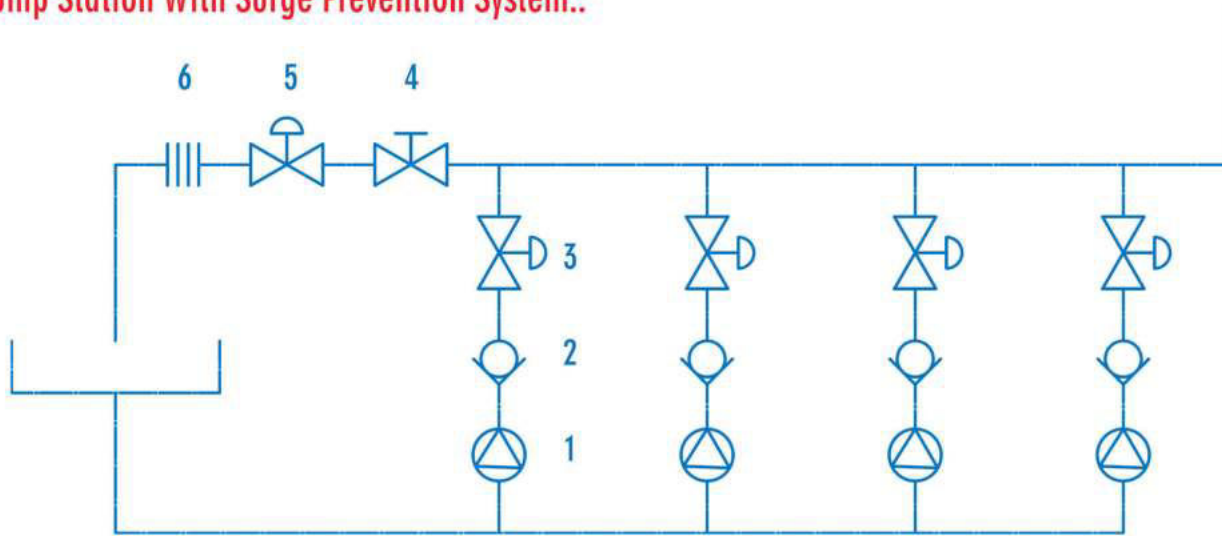

- 1 - Pump
- 2 - Check Valve
- 3 - Pump Discharge Control Valve
- 4 - Manual Isolation Valve
- 5 - Surge Prevention Valve
- 6 - Energy Dissipator

Design & Manufacturing Standards:

The LFC™_3B Surge Prevention valve has been designed in accordance with various international standards as set out below:

ASME Boilers and pressure vessels design code

ANSI B16.10 ANSI B16.3

ANSI B16.34 ANSI B16.37

ANSI B16.5 ANSI N278.1

Available sizes: DN50 / 2" to DN400 / 16"

Face to face dimensions to ANSI B16.10

Pressure rating: up to 2.5 MPa / 363 psi

Available end connections: ANSI B 16.5, BS4504, BS10, AS/NZS 4331.1 (ISO 7005-1) DIN, all makes of grooved or ring joint couplings, and other as per client's requirement.

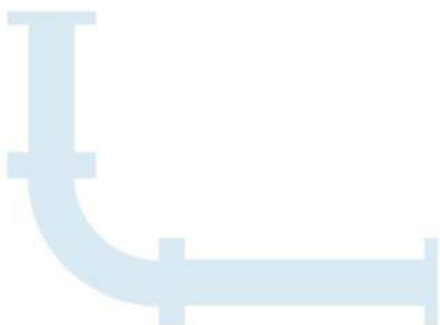



LFC™ _3B Excess Flow Shutdown Valves

Overview:

The LFC™ _3B Excess flow shutdown valve is designed to shut down the flow of water in a piping system when an incident such as a pipe burst, or pipe break occurs. In most water piping systems, an instantaneous shutdown operation can cause a water hammer that could result in serious damage to the piping system. In such a case, water will also continuously run out of the system until it is manually isolated for the problem to be attended to, and as a result a very high volume of water can get wasted. It is often not considered that the high volume of water wastage can substantially increase the cost of operating as well.

In such a case, the flow of water is required to be managed in a controlled manner by the use of a control valve that can gradually close off and reduce the flow of the water. Should there be a valve in the system that can automatically sense the pipe burst or break and shut down automatically such as the LFC™ _3B Excess flow shutdown valve, the risks will be mitigated and the wastage of water can be controlled, which will eventually result in substantial cost savings.

The LFC™ _3B Excess flow shutdown valve works on a very similar principal as a fuse in an electrical circuit, however, a fuse is designed to stop the flow of current instantaneously when the draw exceeds the maximum fuse rating, whereas the LFC™ _3B Excess flow shutdown valve is designed to shut down in a gradual and controlled manner.

The valve is designed to execute this type of operation automatically, and it will start to close off when the desired set-flow (pre-set has been reached, thereby aiding in preventing a water hammer that could cause damage to the piping system from occurring.

The LFC™ _3B Excess flow shutdown valve is designed to present a robust, simple and cost-effective solution to fluid handling issues in any industrial sector, off up to 2.5 MPa / 363 psi.

Design Features:

At the core, the LFC™ _3B range of Excess flow shutdown valves are designed with simplicity in mind. It has one only moving part called the plug assembly, which in effect minimizes the wear and tear of the valve, thereby increasing the valve's overall life span.

The plug assembly is a piston that is engineered to be unbalanced, and uses the valve's inline fluid pressure to control the differential pressures that influences it's operating torque. As such, the valve's operating torque induced by the plug assembly is all that is required to overcome the sum of all counter frictional forces generated by the valve's seals, sleeve, cylinder, and the weight of the plug assembly (depending on the installation configuration).

Under normal conditions, the downstream hydraulic pressure below the plug assembly keeps the valve in the open position via a primary hose arrangement. A secondary hose arrangement is used to feed a hydraulic pressure to the top of the plug assembly; however, the valve will remain open due to the reduced counteracting surface area on top of the plug assembly. The downstream pressure that keeps the valve open gets reduced with the help of the V-port assembly, and only when there is an actual instance of excess flow that takes place, the secondary hose arrangement that feeds the hydraulic pressure to the top of the plug assembly will start to exert a force that moves the plug assembly into the closed position.

As a safety feature, the LFC™ _3B range of Excess flow shutdown valves are design to remain closed when it shuts down and cannot open by itself. When the hydraulic force from the downstream side of the valve that acts below the plug assembly starts to become greater than the hydraulic force from the upstream side of the valve that keeps it closed, only then will the plug assembly start moving to the open position once again.

Alternatively, a 3-way L-Port ball valve can be installed to manually override the excess flow shutdown valve. A qualified operator will be required to manually execute this operation, once the necessary maintenance has been done. When the valve is fully closed, it will remain closed and will not open by itself. The upstream pressure which causes the valve to remain closed can be released by simply opening the 3-way valve (changing the lever position) to vent the fluid that is contained in the valves closing chamber. By closing off the upstream pressure with the 3-way valve and venting the valve's closing chamber, the valve will start to gradually reopen again in a controlled manner. The opening speed of the valve can be controlled with an external variable orifice (needle valve).

A bypass system designed to fill the piping system can also be installed to prevent water hammer and pipe shocking, especially in large bore piping systems. If a bypass system is used, the excess flow shutdown valve will only start opening when the downstream piping is close to reaching the fully charged line pressure. It is recommended to install an air release/vacuum break valve in the piping system after the excess flow shutdown valve, to release the air from the system while it is filling.





LFC™ _3B Excess Flow Shutdown Valves

Dealing With Cavitation:

In most water reticulation and piping applications, most valves will always experience cavitation at the initial opening and final closing stages. The LFC™ _3B Excess flow shutdown valve has been designed to reduce the effects of cavitation on the seating areas by the use of a specially designed V-port device which work in conjunction with the Plug assembly. The Images below shows various open positions of the LFC™ _3B Excess flow shutdown valve's V-port arrangement. This is shown at incremental percentages for illustration purposes.



Figure 1: V-Port Open Positions At Incremental Percentages

Figure 1: 100% Open Position.

This illustration shows the Plug assembly in a 100% open position. Now, it can clearly be seen that the V-port is fully open, and the flow path is only slightly restricted. At this point, the flow is at its full demanded flow rate, and the V-port has little to no function. During a pipe burst or pipe break, the slightly restricted flow path will generate a pressure drop that is sufficient enough for the excess flow shutdown valve to sense a differential pressure and start shutting down. The flow direction is from inside the body seat and V-Port to the outside diameter of the V-Port.

Figure 2: 75% Open Position.

This illustration shows the Plug assembly in a 75% open position. It can clearly be seen that the V-port is almost fully open, and the flow path is still slightly reduced. After a pipe burst or break has occurred, the LFC™ _3B Excess flow shutdown valve will start to close off in a controlled manner and reduce the flow in a linear pattern as it closes.

Figure 3: 50% Open Position.

This illustration shows the Plug assembly in a 50% open position. It can clearly be seen that the V-port is nearly half open, while the flow path is still reduced.

Figure 4: 30% Open Position.

This illustration shows the Plug assembly in a 30% open position. It can clearly be seen that the V-port creates a smaller orifice area, and the flow path is getting reduced. From this point, cavitation needs to be dealt with to increase the life expectancy of the valve. The V-port trim ensures that the seating elements are further apart from each other during a low flow condition, which allows cavitation to take place on the non-critical components of the valve.

Figure 5: 15% Open Position.

This illustration shows the Plug assembly in a 15% open position. It can be observed that the opening is proportionally reduced as the V-port opening becomes smaller at this point, the top of the V-port is exposed to a reduced flow path. This reduces cavitation at the low flow conditions.

Figure 6: 5% Open Position.

This illustration shows the Plug assembly in a 5% open position. It can be seen that the opening at the top of the V-Port just slightly exposed and is very small. This reduces cavitation at low flow conditions.

Figure 7: Closed Position.

This illustration shows the Plug assembly completely seated against the valve body, in a fully closed position. This indicates that the valve is fully closed.

Operating Method:

The LFC™ _3B range of Excess flow shutdown valves are hydrostatically operated and does not require any external equipment such as sensing devices, controllers, actuators, or electrical connections to operate. It can be installed in remote places where there is no access to electricity.

Operating Conditions:

The LFC™ _3B range of valves are designed to operate in systems with relatively clean mediums like water, or other liquids with a low percentage of suspended solids and chlorides. The valve's operating pH range is between 2 - 14 ph.



LFC™ _3B Excess Flow Shutdown Valves

Flow Rates:

Flow (ℓ/sec)		5	10	25	40	50	100	150	200	250	300	350	400
Pressure drop (MPa)	DN50	47	94										
	DN80	17	34	86									
	DN100		23	57	79								
	DN150			26	36	51	102						
	DN200					28	56	84	112				
	DN250						37	55	73	91	112		
	DN300						26	37	50	63	75	90	103
Flow US gallon / min		79.25	158.50	396.26	634.01	792.52	1585.03	2377.55	3170.06	3962.58	4755.09	5547.61	6340.12
Pressure drop (psi)	2"	6.82	13.63										
	3"	2.47	4.93	12.47									
	4"		3.34	8.27	11.46								
	6"			3.77	5.22	7.40	14.79						
	8"					4.06	8.12	12.18	16.24				
	10"						5.37	7.98	10.59	13.20			
	12"						3.77	5.37	7.25	9.14	10.88	13.05	14.94

Material Specifications:

Part Description	Material Specification
Body	Ductile iron
Body seat	431 / 304 S/Steel
Plug	431 / 304 S/Steel
V-port or Seat holder	431 / 304 S/Steel
Shaft	431 / 304 S/Steel
Piston	431 / 304 S/Steel
Plug seat	Polyurethane
Sleeve	431 / 304 S/Steel
Top cover or sleeve holder	Ductile iron
Cylinder	431 / 304 S/Steel
Cylinder holder	Ductile iron
Cylinder top cover	Ductile iron
Indication rod	431 / 304 S/Steel
Hoses	Single braided
Seals	Polyurethane
O-Rings	Bona N

Valve Sizing:

Please consult with a technical expert at Hydromine Projects International for clarification on correct valve sizing on your specific requirements.

Maintenance Requirements:

The LFC™ _3B range of valves require minimal maintenance, the majority of which can be conducted with the valve remaining in situ. All moving parts of LFC™ _3B Excess flow shutdown valve is manufactured from stainless steel which increases their reliability and durability.

Dimensions:

Face to face dimensions: ANSI Class 150 (#150)		
Size	(mm)	(inch)
DN50 / 2"	203	7.99
DN80 / 3"	241	9.49
DN100 / 4"	292	11.50
DN150 / 6"	356	14.02
DN200 / 8"	495	19.49
DN250 / 10"	622	24.49
DN300 / 12"	699	27.52
DN350 / 14"	787	30.98
DN400 / 16"	914	35.98

Design & Manufacturing Standards:

The LFC™ _3B Excess flow shutdown valve is designed in accordance with various International Boiler and Pressure vessel standards, as set out below:

ASME Boilers and pressure vessels design code

ANSI B16.10 ANSI B16.3

ANSI B16.34 ANSI B16.37

ANSI B16.5 ANSI N278.1

Available sizes: DN50 / 2" to DN400 / 16"

Face to face dimensions to ANSI B16.10

Pressure rating: up to 2.5MPa / 363 psi

Available end connections: ANSI B16.5, BS4504, BS10, AS/NZS 4331.1

(ISO 7005-1) DIN, all makes of grooved or ring joint couplings, and various other types, as per client requirements.



LFC™ _5E Range Of Surge Reduction Check Valve

Overview:

The LFC™ _5E Range Of Surge Reduction Check Valve stops reverse flow. It is commonly used in pump stations to stop the pump from running in reverse when the pump is stopped. LFC™ _5E Range Of Surge Reduction Check Valves were designed to reduce the effects of water hammer when the check valve shuts down. Most conventional check valves on the market today only reduce flow in the last 30% of closure resulting in a rapid slamming action which creates water hammer.

The LFC™ _5E Range Of Surge Reduction Check Valves were developed to be more energy efficient with a better flow co-efficient (Cv) than most nozzle check valves on the market today. The nozzle check valve reduces the effects of water hammer but none of our competitors are energy efficient. In pumping systems, energy efficiency is crucial. Energy efficient valves will allow for a maximum amount of fluid to be pumped in the shortest amount of time that the pumping system can deliver. Whereas the time to pump the same amount of fluid with low energy efficiency valves will increase. Over time this will drastically increase the running cost of the pump station due to increased energy requirements as well as wear and tear on pumps and valves.

The LFC™ _5E Range Of Surge Reduction Check Valve has been developed to present a robust, simple and cost effective high pressure (up to 25 MPa / 3 626 Psi) solution to fluid handling issues in any industrial sector.

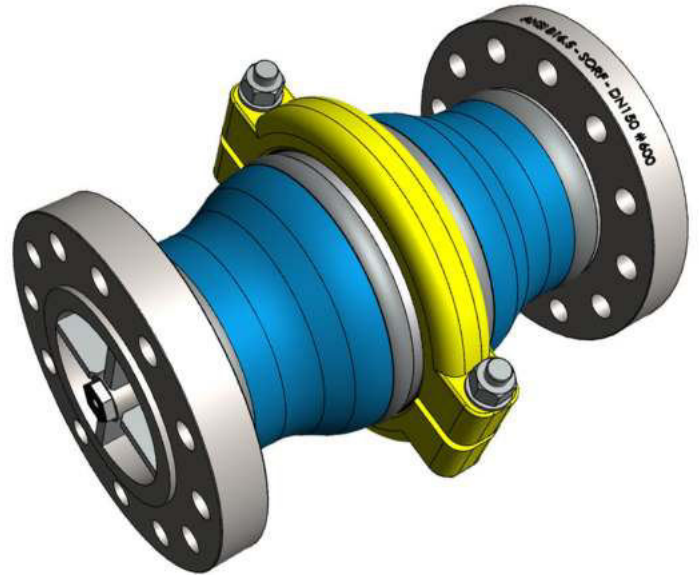

Operating Conditions:

These valves are designed to operate in systems with relatively clean media like water or other liquids with a low percentage of suspended solids and chlorides. The valve's operating pH range is 2 – 14 pH.

Simplicity:

The LFC™ _5E Range Of Surge Reduction Check Valve, disc is shaped to allow for a smoother flow path around it. The disc is carried by a shaft that can slide in two guides on the inlet and outlet side of the LFC™ _5E Range Of Surge Reduction Check Valve body. On the outlet side of the Surge Reduction Check Valve body guide, the guide is partly closed creating a compartment. By closing the compartment partly, during a closing operation a vacuum is created inside the compartment of the guide. This prevents the disc from slamming shut and the LFC™ _5E Range Of Surge Reduction Check Valve therefore closes in a controlled manner which drastically reduces the occurrence of water hammer.

By carrying the disc on a shaft, bushes and guides, we increase the life of the LFC™ _5E Range Of Surge Reduction Check Valve when compared to conventional check valves. Conventional check valves all have a hinge systems attached to the door / disc. These hinge systems are not very reliable as the hinges wear out and prevent the door /disc from closing to the correct position causing the check valve to leak and fail.

A spring is installed in the LFC™ _5E Range Of Surge Reduction Check Valve to keep it in the closed position for commissioning. After the system is charged with pressure, the pressure acts on the moving wetted parts and forces the LFC™ _5E Range Of Surge Reduction Check Valve closed and the spring serves no purpose. Once the pump starts or the pressure is higher from the inlet side of the LFC™ _5E Range Of Surge Reduction Check Valve, the higher pressure pushes the check valve disk open.

Low Maintenance Requirement:

LFC™ _5E Range Of Surge Reduction Check Valve only has one moving part making it very reliable. It is manufactured from stainless steel which increases reliability and durability. LFC™ _5E Range Of Surge Reduction Check Valve requires minimal maintenance which is made easy by its split body configuration.





LFC™_5E Range Of Surge Reduction Check Valve

The Effects Of Water Hammer:

See the effects of water hammer on an underground pump station with 770m static head in an Mine when 1 pump was tripped using a conventional double door check valve.

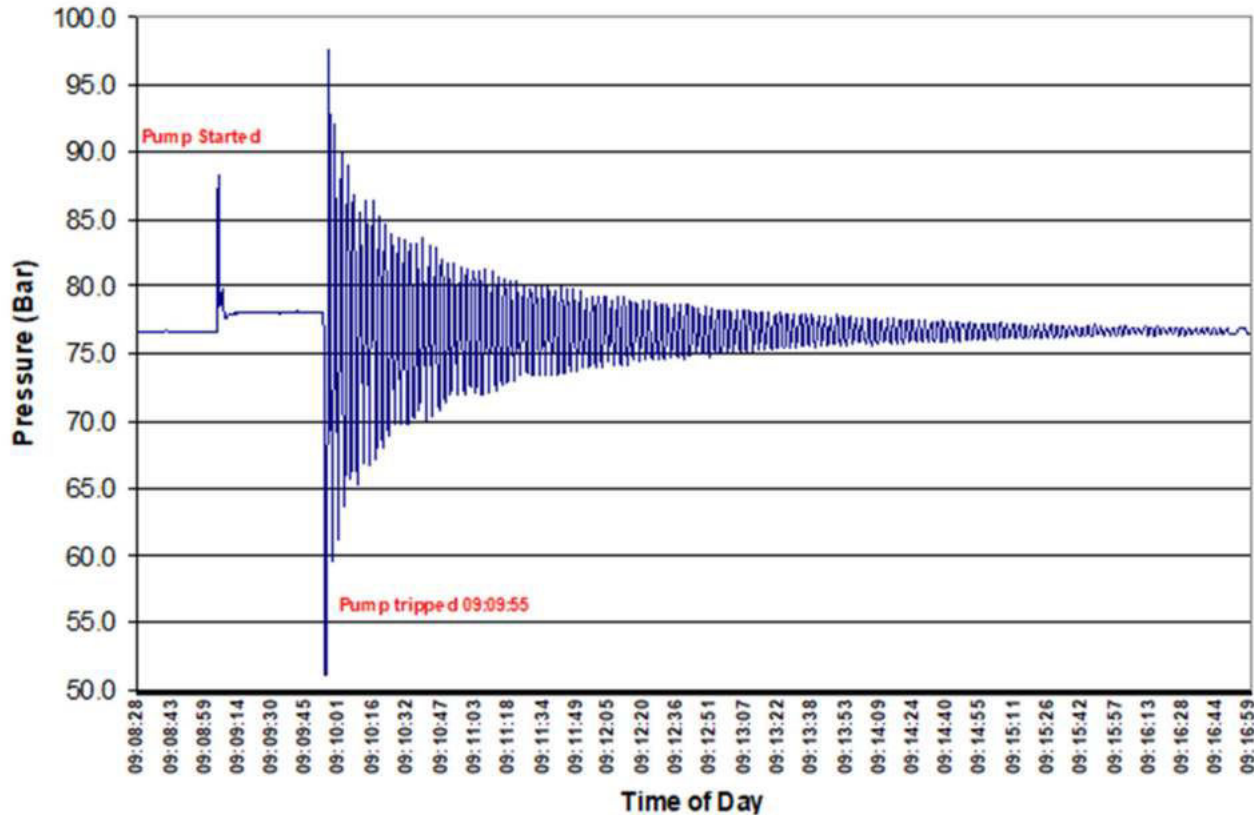

The Effects Of Using A LFC™_5E Range Of Surge Reduction Check Valve:

See the effects of how installing the LFC™_5E Range Of Surge Reduction Check Valve drastically reduced the severity of the water hammer at the underground pump station in a Mine with a static head of 1192m when 1 pump was tripped.

Diagram 1

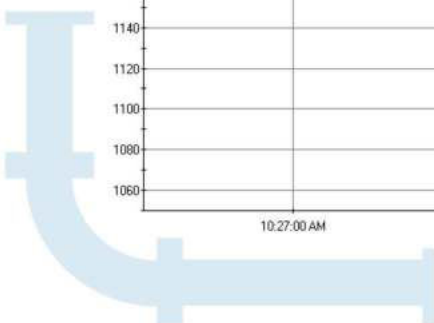
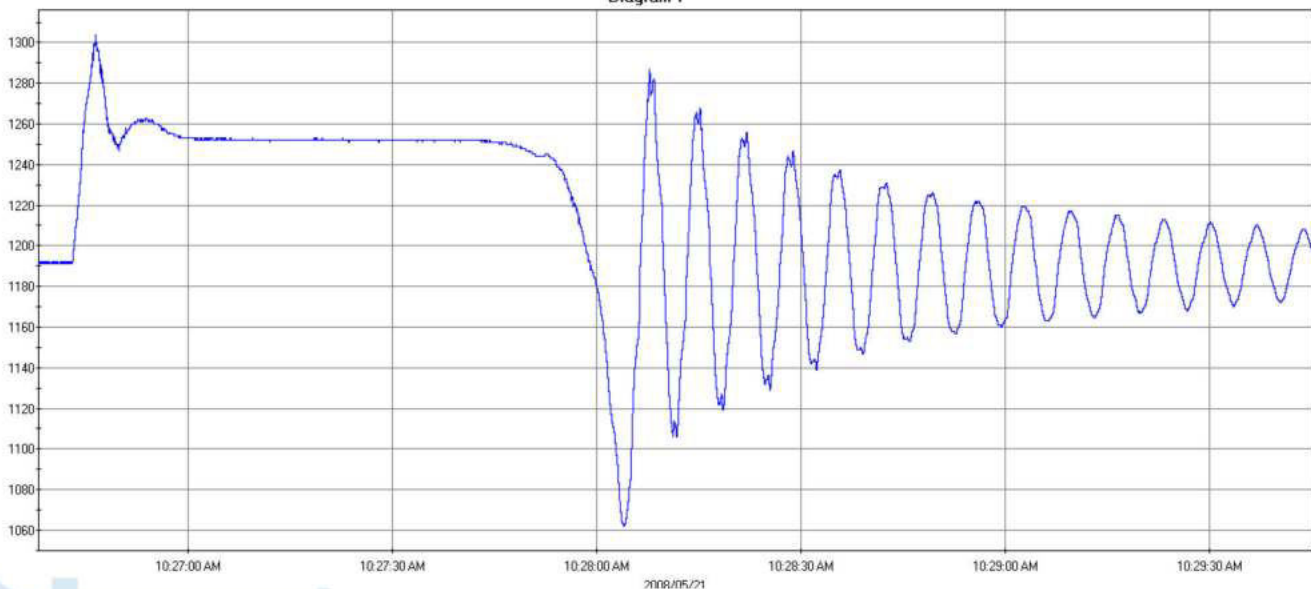



LFC™ _5E Range Of Surge Reduction Check Valve

Materials Of Construction & Dimensions:

Part Name	Specification	Unit	Face to face dimensions					
			#600		#900		#1500	
			(mm)	(inch)	(mm)	(inch)	(mm)	(inch)
Intel body	Casting - BS3100 Gr. A2	DN100 / 4"	431	16.97	457	17.99	546	21.50
Inlet body seat #1	309 S/Steel	DN150 / 6"	559	22.01	610	24.02	705	27.76
Inlet body seat #2	F6	DN200 / 8"	660	25.98	737	29.02	832	32.76
Inlet body seat #3	F12	DN250 / 10"	787	30.98	838	32.99	991	39.02
Outlet body	Casting - BS3100 Gr. A2	DN300 / 12"	838	32.99	965	37.99	1130	44.49
Flanges	ASTM A105	DN350 / 14"	889	35.00	1029	40.51	1257	49.49
Disc	431 S/Steel	DN400 / 16"	991	39.02	1130	44.49	1384	54.49
Shaft	431 S/Steel							
Shaft bush	LG 2							
Guide bush	431 S/Steel							
O-Rings	Nitrile (Buna)							
Clamps	BS3100 Gr. A2							

Flow Rates:

Flow (ℓ/sec)		25	35	50	100	150	200	250	300	350	400
Pressure drop (kPa)	DN100	7	12								
	DN150	4	5	8	27						
	DN200			4	8	16	34				
	DN250				2	5	10	15	24		
	DN300					4	9	13	17	22	25
Flow US gallon / min		396.26	554.76	792.52	1585.03	2377.55	3170.06	3962.58	4755.09	5547.61	6340.12
Pressure drop (psi)	4"	1.02	1.74								
	6"	0.58	0.75	1.16	3.92						
	8"			0.58	1.16	2.32	4.93				
	10"				0.29	0.75	1.45	2.18	3.48		
	12"					0.58	1.31	1.89	2.47	3.19	3.63

Design & Manufacturing Standards:

LFC™ _5E Range Of Surge Reduction Check Valve has been designed in accordance with various international standards as set out below:

ASME Boilers and pressure vessels design code

ANSI B16.10 ANSI B16.3

ANSI B16.34 ANSI B16.37

ANSI B16.5 ANSI N278.1

Available sizes: DN50 / 2" to DN600 / 18"

Pressure rating: up to 25MPa / 3 626 psi

Face to face dimensions: ANSI B16.10 or other, minimum #600

Available end connections: ANSI B16.5, BS4504, BS10, AS/NZS 4331.1 (ISO 7005-1) DIN, all makes of grooved or ring joint couplings, and other as per clients requirement.





LFC™_7 Energy Dissipators

Overview:

The LFC™_7 energy dissipator is a custom designed piece of equipment that reduces the upstream pressure to the designed ratio at a specific designed flow rate.

The LFC™_7 energy dissipator has been developed to present a robust, simple and cost effective method to reduce pressure at a set flow rate in open ended pipes. It will typically be used with a dam level control valve or a column drain valve. The dissipator will ensure that the pressure is discharged from the open end at a safe pressure. The LFC™_7 energy dissipator will increase the life of the valve upstream of it as the valve will not be required to throttle or break pressure. The high wear task is undertaken by the dissipator .

Operating Conditions:

The LFC™_7 energy dissipator have a series of orifices that break pressure and reduce flow over each stage.

Noise Level:

The LFC™_7 energy dissipator is relatively quiet compared to other dissipators in the market place.

Dimensions:

Unit	Face to face dimensions (popular sizes only)									
	#150		#300		#600		#900		#1500	
	(mm)	(inch)	(mm)	(inch)	(mm)	(inch)	(mm)	(inch)	(mm)	(inch)
DN50 / 2"	203	7.99	267	10.51	292	11.50	368	14.49	368	14.49
DN80 / 3"	241	9.49	318	12.52	356	14.02	381	15.00	270	10.63
DN100 / 4"	292	11.50	356	14.02	431	16.97	457	17.99	546	21.50
DN150 / 6"	356	14.02	445	17.52	559	22.01	610	24.02	705	27.76
DN200 / 8"	495	19.49	559	22.01	660	25.98	737	29.02	832	32.76
DN250 / 10"	622	24.49	622	24.49	787	30.98	858	32.99	991	39.02
DN300 / 12"	699	27.52	711	27.99	838	32.99	965	37.99	1130	44.49
DN350 / 14"	787	30.98	762	30.00	889	35.00	1029	40.51	1257	49.49
DN400 / 16"	914	35.98	838	32.99	991	39.02	1130	44.49	1384	54.49

Design & Manufacturing Standards:

The LFC™_7 Energy Dissipator Range has been designed in accordance with various international standards as set out below:

ASME Boilers and pressure vessels design code

ANSI B16.10 ANSI B16.3

ANSI B16.34 ANSI B16.37

ANSI B16.5 ANSI N278.1

Available sizes: DN12 / 1/2" to DN1000 / 40"

Pressure rating: up to 25MPa / 3 626 psi

Face to face dimensions: ANSI B16.10

Available end connections: ANSI B16.5, BS4504, BS10, AS/NZS 4331.1 (ISO 7005-1)

DIN, all makes of grooved or ring joint couplings, and other as per clients requirement.

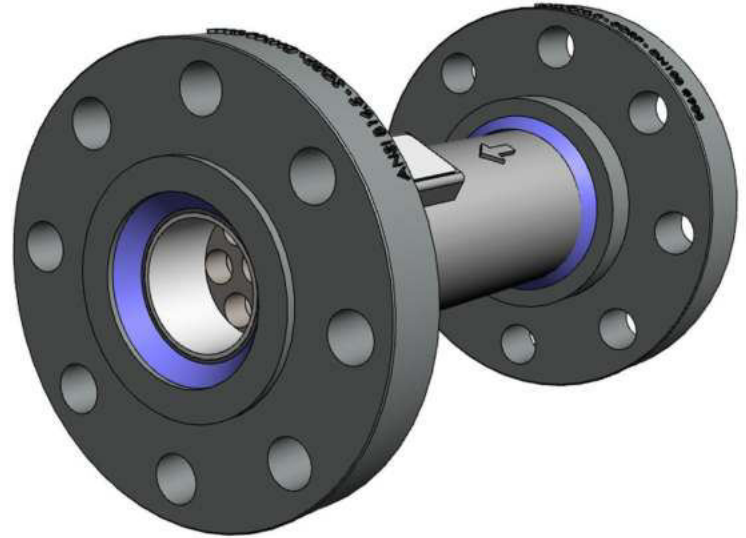

Materials Of Construction:

Part Name	Material Specification
Body #1	ASTM A105 Grade B
Body #2	Hollow bar ST52
Stages	431 S/Steel hardened
Spacers	ASTM A105 Grade B
Stopper	Carbon steel



LFC™ _22 Pinch Type Manual Isolation Valve (BARET Valve)

Overview:

The LFC™ _22 Pinch type Manual Isolating valves (BARET Valve) were designed to be simple and easy to operate.

The LFC™ _22 Pinch type Manual Isolation valve has been developed in conduction with Zimbabwe Valve's "BARET Valve" to present a robust, simple and cost effective (up to 2.5 MPa / 363 psi) solution to abrasive liquids handling issues in any industrial sector.

Operating Conditions:

The BARET Valve have a long history, being used in applications with slurries, pulps and a wide range of aggressive fluids, which are often difficult and costly to manage using other types of valves, such as gate, knife gate etc. The natural rubber sleeve formulation gives good wearing characteristics and long work life.

Simplicity:

The LFC™ _22 Pinch type Manual Isolation valve (BARET Valve) is designed to minimize wearing parts. It is operated by a rising spindle, handwheel mechanism. The benefit of the rising spindle is that one can immediately see if the valve is open, close or partly open. As opposed to non-rising spindle valves where the valve position cannot be determined at a glance.

Low Maintenance Requirement:

The LFC™ _22 Pinch type Manual Isolation valve (BARET Valve) sleeves are relatively easy to change should it be worn or ruptured. The bearings can be changed, with the valve remaining in situ, in the open position. A grease nipple in the bearing box enables easy lubrication of bearings. The rising spindle makes lubrication and cleaning easy. Lifting holes makes handling and installation easier.

Robust, Reliable & Efficient:

The valve body are fabricated (as opposed of being cast), and it's structure a good rigid transfer of pipeline forces. The sleeve is well protected, in the tubular housing against external agencies, including sunshine, and damage by outside interference.

Flow Rates:

The valve offers a free flow with no flow restriction.

Actuation:

A wide range of electrical, pneumatic, and hydraulic actuators can be fitted on the valve.

Materials of Construction & Dimensions:

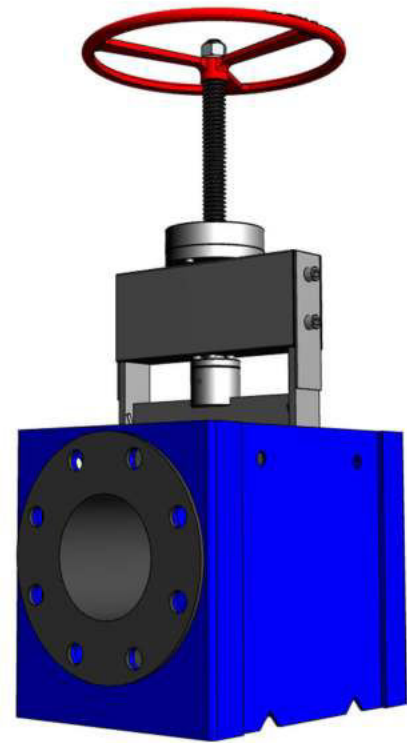

Part name	Material Specification	Valve size	Maximum Pressure Rating		Face to face	
			(MPa)	(psi)	(mm)	(inch)
Body	Fabricated carbon steel					
Sleeve	Natural rubber	DN50 / 2"	2,5	362,6	190	7,48
Spindle	431 S/Steel	DN80 / 3"	2,5	362,6	255	10,04
Bearing box	431 / 304 S/Steel	DN100 / 4"	2,5	362,6	305	12,01
Driving bush	LG 2	DN150 / 6"	2,5	362,6	406	15,98
Bearings	Thrust bearings	DN200 / 8"	1,6	232,06	520	20,47
		DN250 / 10"	1	145,04	635	25
		DN300 / 12"	0,6	87,02	750	29,53



LFC™ _22 Pinch Type Manual Isolation Valve (BARET Valve)

Design & Manufacture Standards:

The LFC™ _22 Pinch type Manual Isolation Valve (BARET Valve) has been designed in accordance with various international standards.

Available sizes: DN50 / 2" to DN300 / 12"

Pressure rating: up to 2.5 MPa / 363Psi

Available end connections: ANSI B16.5, BS4504, BS10, AS/NZS 4331.1 (ISO 7005-1) DIN and other as per client's requirement.

Manufacturing Standards:

The BARET Valve has been manufactured to an ISO 9002 Quality Assurance System since 1994

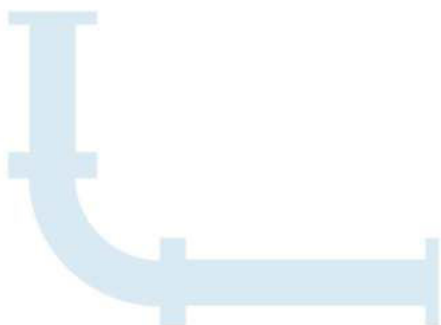



LFC™ _22 Pinch Type Surge Prevention Valve (BARET Valve)

Overview:

The LFC™ _22 Pinch Type Surge Prevention System is designed to prevent water hammer or pressure surges in dirty water or slurry pumping systems. Especially in mining applications. Water hammer (or, more generally, fluid hammer) is a pressure surge or wave resulting when a fluid in motion is forced to stop or change direction suddenly (Momentum Change).

Hydromine used their tried and tested LFC™ _1B high pressure surge prevention system concept and combined the technology with the tried and tested BARET Valve from Zimbabwe Valve to develop the LFC™ _22 Pinch Type Surge Prevention System. It presents a robust, simple, and cost effective (up to 2.5 MPa / 363 psi) solution to abrasive liquids handling issues in any industrial sector.

Water hammer commonly occurs when a pump is stopped suddenly, and a pressure wave propagates in the pipe. It is a force that can arise in any pumping system that undergoes abrupt changes in its rate of flow. These flow changes can result from pump starts and stops, the opening and closing of valves, and column separation and closure. The piping design does have an effect upon water hammer but, we have identified the main conditions resulting in hammer.

When Does Water Hammer / Pressure Surge Occur?

Water hammer will normally occur in a pumping system when one of 3 conditions occur:

1. A total power failure, causing all the running pumps to trip.
2. The emergency stop is activated on the last running pump.
3. Tripping of the last running pump.

Water Hammer / Pressure Surge:

Typically, water hammer travels at the speed of sound through its medium which can amount to 1 481 m/s (Ave 995m/s) in water. Water is only partially compressible. At ambient temperature one pound of pressure will decrease its volume by a factor of about 0.0000034. The larger the volume of water, the easier it is to see the effect of water hammer. Compression begins at the leading edge of the water column and when the additional energy it produces cannot continue on past the closed valve (Non-Return valves), a pressure or shock wave is generated which travels back upstream. The inception of this shock wave is very similar to the "echo" that is produced when a sound wave, traveling through air, strikes some barrier. When the wave hits the upstream valve, it is reflected back downstream but with a diminished intensity. This, back and forth, motion continues until friction and reflection losses cause the waves to dissipate. The speed at which a wave travels and the energy it loses during travel depends upon the density and compressibility of the medium in which it is traveling. It turns out that the density and compressibility of water make it a very good medium for shock wave generation and transmission.

Simplicity:

The LFC™ _22 Pinch Type Surge Prevention Valve System is designed to minimize wearing parts. The LFC™ _22 Pinch Type Surge prevention valve is oil hydraulically actuated using a small hydraulic power pack to actuate.

This rapid displacement of oil stored in an accumulator under pressure causes the LFC™ _22 Surge Prevention valve to open extremely quickly.

Low Maintenance Requirement:

All the actuator parts of the LFC™ _22 Pinch Type Surge Prevention Valves are manufactured from stainless steel which increases reliability and durability. The LFC™ _22 (BARET Valve) sleeves are relatively easy to change should it be worn or ruptured. Lifting holes makes handling and installation easier.

Operating Conditions:

The BARET Valve have a long history, being used in applications with slurries, pulps and a wide range of aggressive fluids. The natural rubber sleeve formulation gives good wearing characteristics and long work life.

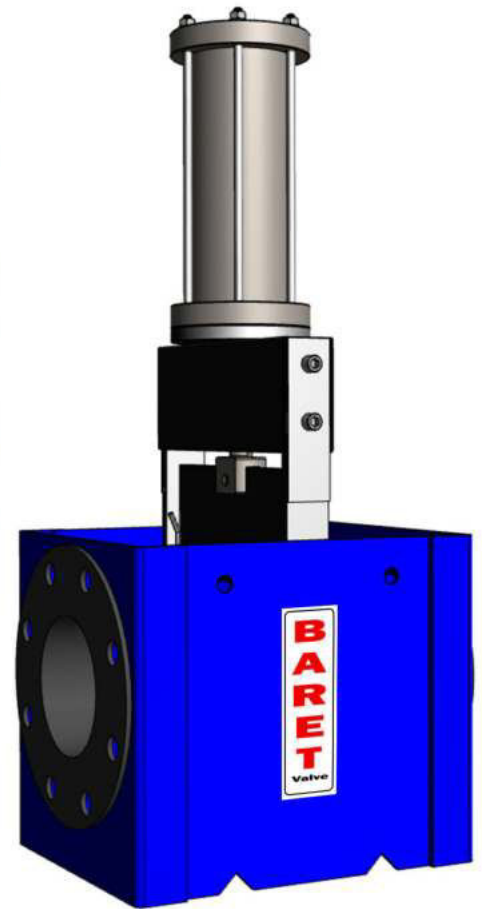



LFC™_22 Pinch Type Surge Prevention Valve (BARET Valve)

The Effects Of Water Hammer / Pressure Surge:

The graph shows the effects of water hammer on a pump station in an Mine, with an underground pump station of 770m static head when 1 pump tripped.

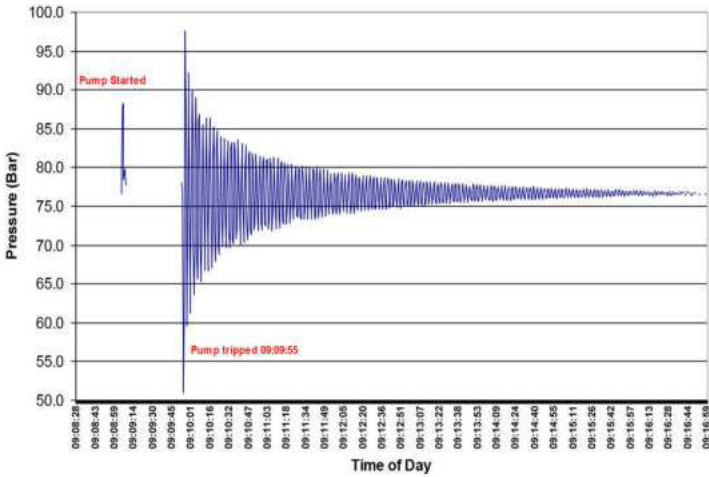

The graph shows the effects of water hammer in a Mine pump station, with an underground pump station of 786m static head when 2 pumps tripped.

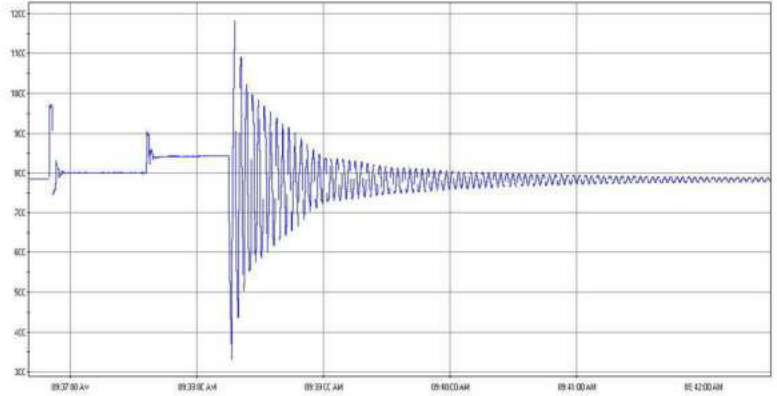

How Does It Work?

The LFC™_22 Pinch Type Surge Prevention Valve opens rapidly when there is an abrupt stop of the last running pump, or a total power failure during dewatering. At that stage the flow is still moving away from the pump station, but as soon as it loses its driving force and energy it will start returning towards the pump station. Due to the open LFC™_22 Pinch Type Surge prevention valve, the returning column of water is met with an open orifice and an exit point for any energy build up.

The flow moves through the surge prevention valve and energy dissipator installed after the valve. After keeping the LFC™_22 Pinch Type Surge Prevention Valve open for +/- 10 seconds, the surge prevention valve starts closing in a controlled manner to prevent any surging. The function of the energy dissipator is to discharge the flow at safe pressure and a set flow to atmosphere into the suction dam or drain.

The graph on the left shows the effects of water hammer on an underground pump station with 920m static head when 1 pump tripped. The graph on the right shows the result of using the LFC™_1B surge prevention valve system in the same pump station, when 1 pump tripped. It clearly demonstrates the effectiveness of the solution and shows that no water hammer was experienced.

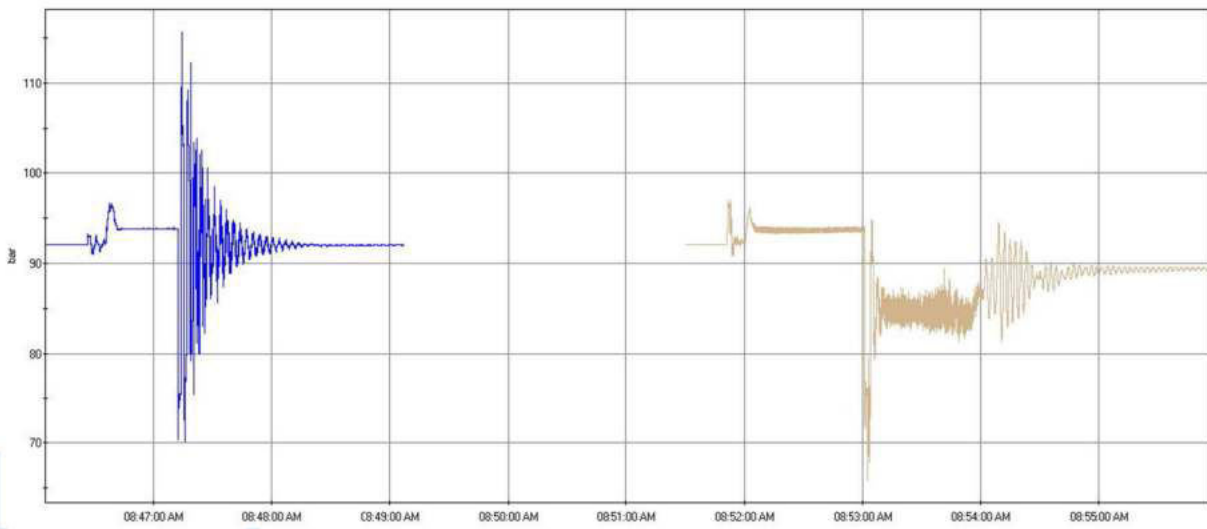
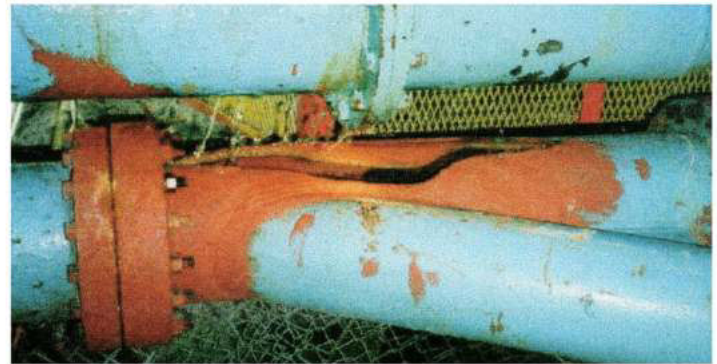



LFC™ _22 Pinch Type Surge Prevention Valve (BARET Valve)

LFC™ _22 Pinch Type Surge Prevention System with Compact Oil Hydraulic Power Pack:

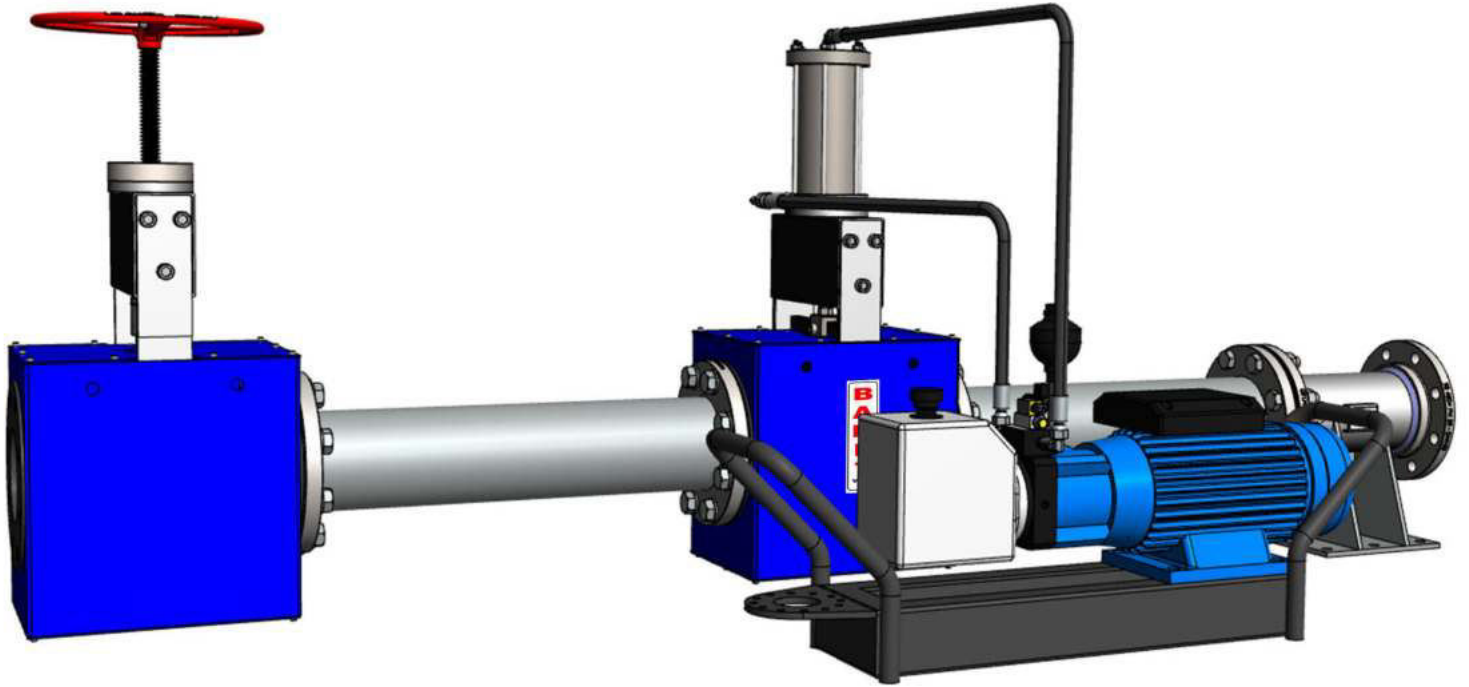

Typical Pump Station With Surge Prevention System.:

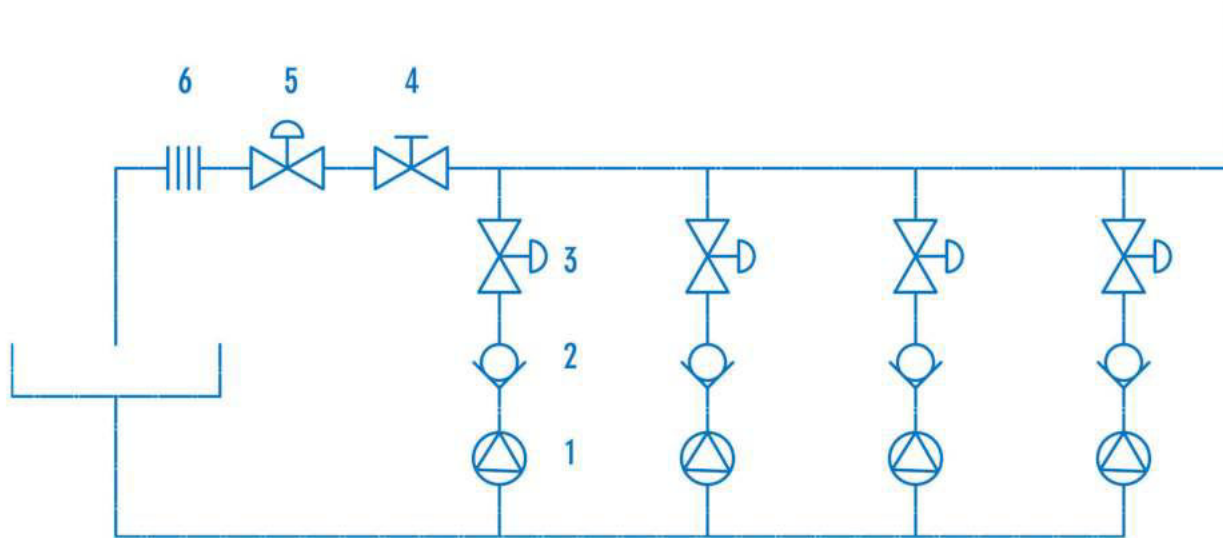

- 1 - Pump
- 2 - Check Valve
- 3 - Pump Discharge Control Valve
- 4 - Manual Isolation Valve
- 5 - Surge Prevention Valve
- 6 - Energy Dissipator



LFC™ _22 Pinch Type Surge Prevention Valve (BARET Valve)

Surge Prevention System:

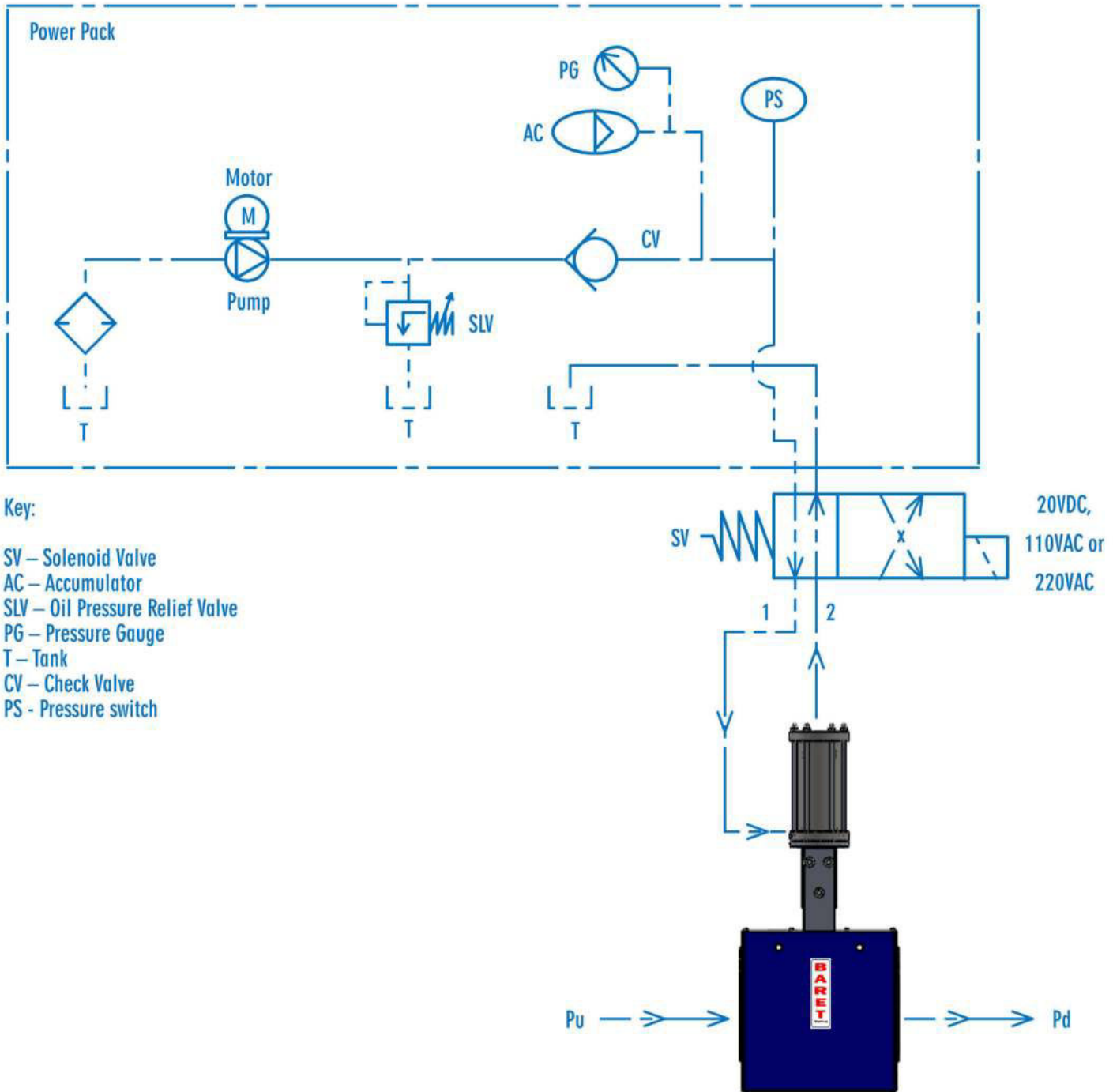

Materials of Construction & Dimensions:

Part name	Material Specification	Valve size	Maximum Pressure Rating		Face to face	
			(MPa)	(psi)	(mm)	(inch)
Body	Fabricated carbon steel					
Sleeve	Natural rubber	DN50 / 2"	2,5	362,6	190	7,48
Piston rod	431 S/Steel	DN80 / 3"	2,5	362,6	255	10,04
Cylinder	431 / 304 S/Steel	DN100 / 4"	2,5	362,6	305	12,01
Cylinder end caps	431 S/Steel	DN150 / 6"	2,5	362,6	406	15,98
Piston	431 S/Steel	DN200 / 8"	1,6	232,06	520	20,47
Seals	Polyurethane	DN250 / 10"	1	145,04	635	25
O-Rings	Nitrile (Buna)	DN300 / 12"	0,6	87,02	750	29,53



LFC™ _22 Pinch Type Surge Prevention Valve (BARET Valve)

Design Standards:

The LFC™ _22 Pinch Type Surge Prevention Valve (BARET Valve) has been designed in accordance with various international standards.

Available sizes: DN50 / 2" to DN300 / 12"

Pressure rating: up to 2.5 MPa / 363Psi

Available end connections: ANSI B16.5, BS4504, BS10, AS/NZS 4331.1 (ISO 7005-1) DIN and other as per client's requirement.

Manufacturing Standards:

The BARET Valve has been manufactured to an ISO 9002 Quality Assurance System since 1994

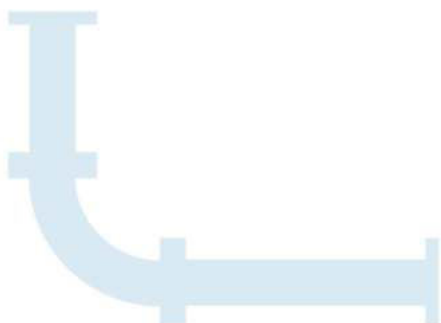



VALVES

Product Range



SCAN ME



Contacts Us:-

- +91- 9829132777
- info@tesca.in
- www.tescaglobal.com

Tesca Technologies Pvt. Ltd.

IT-2013, Ramchandrapura Industrial Area, Sitapura Extension,
Near Bombay Hospital, Vidhani Circle, Jaipur-302022, Rajasthan, India,
Tel: +91-9829132777; Email: info@tesca.in, tesca.technologies@gmail.com

Tesca Technologies Pvt. Ltd.



Tesca Mining Products *Brochure*

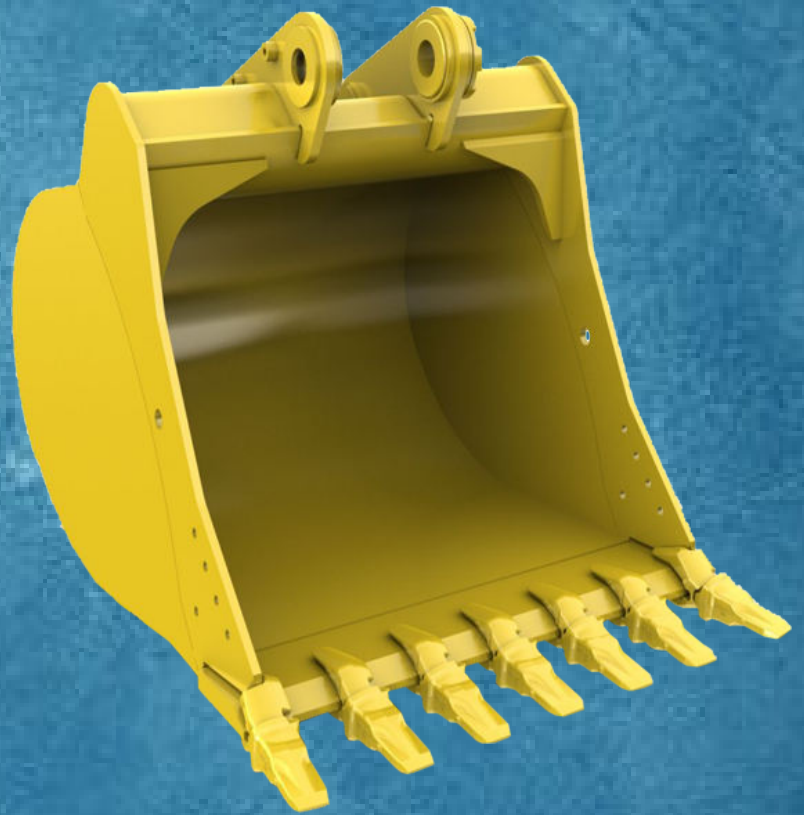

 +91- 9829132777

 info@tesca.in

 www.tescaglobal.com

In This Product Range we Have High Quality Standards | LFC Range of High Pressure Isolating | Safety & Control Valves | Low Pressure Safety & Control Valves | Energy Dissipaters & Expansion Joints and other Mining Application Tools, Equipment & Accessories.



Expansion Joints and Bellows

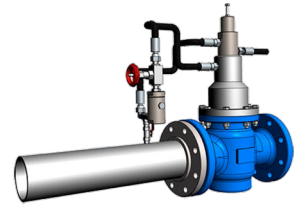

Range of Low Pressure Valves

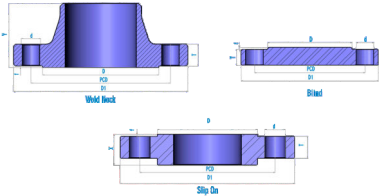

Pipe Fittings Flanges and Fabrication

Range of Medium to High Pressure

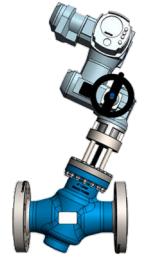

Pipe Jointing Couplings

Range of Pinch Valves Up To PN25

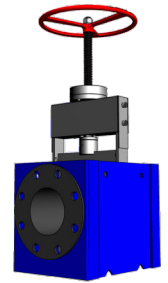

Pressure Gauges

Range of Strainers

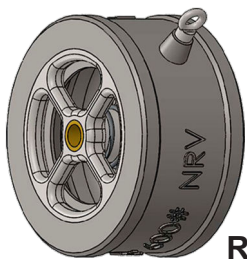

Range of Check Gate and Butter

Range of Surge Reduction Check Valve

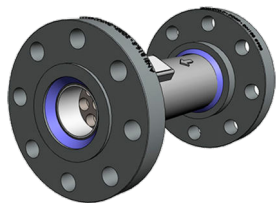
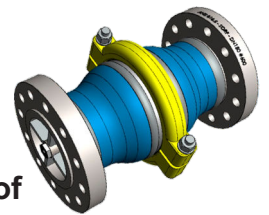

Range of Energy Dissipaters

Rhino Reels Heavy Duty Fire Hose Reels





Spiral Wound and Ring Gaskets



Mining Cap lights



Mining Pickaxe

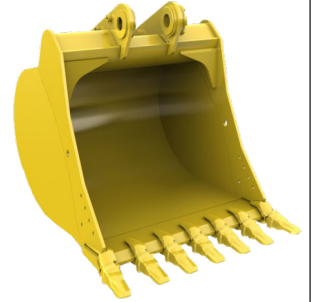

Bucket Excavator

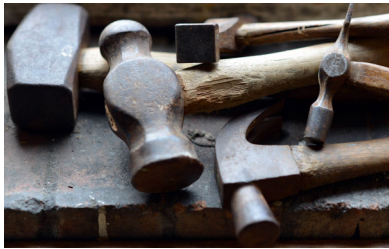

Mining Hammer



Conveyor Belt



Chisels



Refuge Chambers



Shovels



Rock Duster



Air respirator system



Drones



worlddidac
M E M B E R C E



Tesca *Mining* *Products*

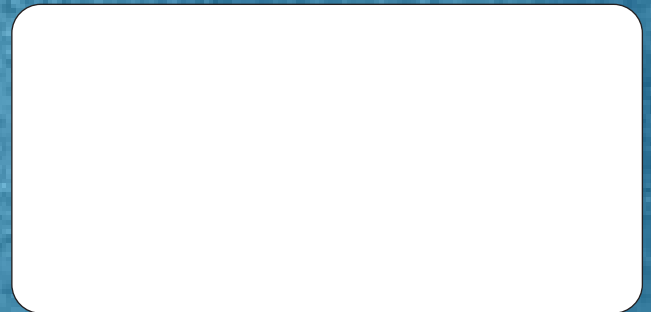

SCAN ME

Tesca Technologies Pvt. Ltd.

IT-2013, Ramchandrapura Industrial Area, Sitapura Extension,
Near Bombay Hospital, Vidhani Circle, Jaipur-302022, Rajasthan, India,
Tel: +91-9829132777; Email: info@tesca.in, tesca.technologies@gmail.com

www.tescaglobal.com